



ENG

# AKKAYALAR CONVEYOR



<b>CONVEYOR SYSTEM</b>	02
<b>ROLLERS</b>	04
Impact Rollers	12
Lower Return Rollers With Rubber Discs	13
Guide Rollers	20
<b>CHASSIS</b>	25
Side Brackets for Return Roller	31
<b>DRUMS</b>	35
Driving Drum	37
Tail / Tension Drum	40
Elevator’s Driving and Tail Drums	43
Cleaning Drum with Rod	43
Drum Spares	44
<b>TAPER LOCK SYSTEMS</b>	44
<b>BEARING HOUSING</b>	45
<b>RUBBER DISCS</b>	46

*To satisfy customers’ requests with most convenient quality and most eligible price within suitable time; to train the personnel continuously in order to develop quality of product and service; to benefit by creativity of employees in order to gain the Customer Satisfactions awaraness, Quality and Productivity, to be an sensitive enterprise to environment and looking the future with confidence are our main principles.*

**Our Quality Policy**

*Our firm which acts with its principles, is paying attention to Standard and Quality has initiated Quality Management application which takes TS-EN-ISO 9001-2015 as basis on 30.04.2016 as necessity of the future pursuant to today’s requirements along with the development process started as TSE Quality Certificate on 26.02.2002 to products.The system that products are produced with the certificates taken on this matter is registered as internationally recognized system.*

*Our firm has registered its brand with brand no 2006 00207 on 03.01.2006 by Turkish Patent Institute.*

*In addition, authorization to use CE mark on 06.09.2010 from Ministry of Industry has been taken for CONVEYOR SYSTEM.*

Our firm which gives importance to quality, environment and its products, along with certifying and maintaining its ISO 9001-2015 Quality Management System to its quality works started in March 2006, has proven that its manufactured rollers comply with ATEX criteria with its ATEX certificate dated 21.08.2013. With its ISO 14001-2015 Environment Management System dated 26.11.2014, it has shown that it is susceptible to environment and sensitive on OHSAS 18001:2015 Occupational Health and Safety issues.

**Our mission:**

We are believing that the conveyor users have the right to have long-life conveyors, so as Akkayalar Conveyor family, we do our best to manufacture high quality spare parts such as rollers, pulleys and stations for our valuable customers to satisfy their needs.

**Our vision:**

To become a leader producer of conveyor system spare parts in this sector with principles and innovative approach, problem solving attitude and sense of quality.



Our firm has been established in 1987 as a family company, and registered as Akkayalar Machine Industry and Trade Limited Company on 12 March 1997 with two partners, and still continues its way on conveyor sector.

Our foundation objective is to manufacture conveyor transport system which we call “transmission and conveyor with belt or without belt”, used in bulk material transport industry and to produce belonging spare parts and provide end users, engineering firms and machine producers with them in domestic and international market.

Our target is raising our market share to the highest level by giving particular importance to quality in domestic and international market with suitable technologic equipment with sense of management, conscious and expert staff and sustaining in this way.

**AKKAYALAR CONVEYOR** is working on conveyor equipment used in bulk handling industry since its establishment. **AKKAYALAR CONVEYOR** is the market leader in Turkey today, and working with leading Equipment Manufacturers, Engineering Firms and end user groups in domestic and international market on this field.

**AKKAYALAR CONVEYOR** manufactures spare parts of conveyors used in bulk material handling industry such as pulleys/drums, rollers and chassis, and auxiliary components such as bearing housing, rubber discs, complementary parts of chassis, connection parts, and conical tightening clamps, etc.

**AKKAYALAR CONVEYOR** prefers to focus only on production of spare parts. This preference provides us additional value to support our small or big customers such as conveyor producers, system engineers or end users in their fields of activity and in our market.

In 2012 by the aim of increasing the production capacity, it moved to its new location with 5.000m of 15.000m area is indoor at Sincan 1st OSB (Organized Industrial Region). It continues the development process by renewing machinery with the latest technologies, in manufacturing, painting and mounting lines. It is also able to apply tests for manufactured rollers according to DIN 22112-3 norm in its well equipped Laboratory, and report the results to customers in case of their request.

## CONVEYOR SYSTEM

Belt conveyors are transport system used for transmission of solid materials in large quantities to far distances in horizontal or vertical in certain limits. There are two types of manufacturing: fixed and mobile. In the following figure, primary components of belt conveyor are shown.

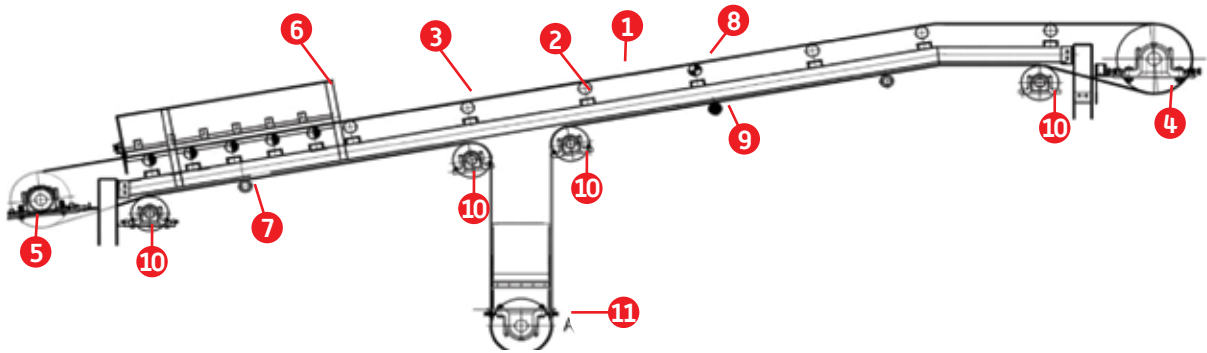

Transmission belt [1] moves on transport rollers [3] mounted on transport chassis [2]. Driving force is transmitted to belt as a result of friction through single or double driving drum [4]. In order to ensure friction, belt is subject to pretensioning with the help of tensioning/tail drum [5]. Filling of belt with material is provided with filling station [6]. Lower return roller [7] ensures transmission belt goes straight and it does not decline below. Upper adjusting station [8] and lower adjusting station [9] prevent slide of belt at long distances. Diversion drums [10] provide good surrounding of transmission belt on drums. Weight tension drum [11] also enables tension of belt for long conveyors.

Movement apparatus of belt and belt cleaners are needed for smooth movement of belt in many plants. Transport of all kinds of materials dry or wet with belt conveyors is very eligible especially for (abradable) materials like sand, sintered coke, stone, etc.

Average inclination which may be applied for material transport in inclined should not exceed 20 degrees. In terms of operation temperature, belt conveyors are normally used between -45°C for cold environments up to 125°C and special synthetic belts up to 150°C.

Conveyors at various lengths and characteristics from mobile conveyors of 3-5 m to fixed plant conveyors of a few hundreds can be manufactured.

In addition, by operating conveyor in a way to make loading each other, it is possible to rise transmission distance to a few kilometers. Material quantity that belt conveyors transport can reach from a few tons in mobile belts to 20.000 tons in belts with 3 m width. Also the belt transporting velocity can increase up to 8-10m/s.

The frame bearing conveyor system consists of a simple girder construction. So belt conveyors are also very eligible for material transport in light mountainous land, over river and in tunnel.

## **PLACES WHERE BELT CONVEYORS ARE BEING USED**

Belt conveyors are being used in many fields like loading, unloading, storing and receiving from storage as well as material transfer. Commonly:

### **1. Mine Pits;**

The most important factor of enterprise economy is material transport for production of raw material and ore in mine shafts. In this case, material transport is composed of a range of procedure from mine shaft to refining including crushing, grinding, sieving, washing, concentration works and transport of wastes. Later it is storing of material obtained from there in enterprise and loading to vehicles for transport by road, railway or sea.

### **2. Power Plants;**

Material storing and transport problem is one of the points considered in contemporary power plants. In fact, belt conveyors are used as only method to be used for transportation of coal from wagons or vessels to hoppers. With a main conveyor and side distribution conveyors, it is probable to distribute and store coal on land easily and reshipment to hoppers. Again, the most suitable vehicle for these procedures is belt conveyors.

### **3. Cement Factories and Concrete Preparing Operators;**

Conveyors are needed at cement factories and concrete preparing operators of preparing agrega (crushed stone), their storage and transfer to elevators. It provides related products to transfer in a very short time and continuously.

### **4. Port Handling Plants;**

Material transport in large tonnages and in the shortest time is requested for handling of the materials such as ore, coal, cereal etc. in ports. Therefore fixed and mobile belt conveyors are used in port enterprises.

### **5. Other Places of Use;**

Belt conveyors, in addition are being used in earthmoving and concrete preparation plants in constructions such as dam, road, bridge, etc. Besides, it is used for transport, preparation of moulding sand, distribution it to moulding machines and return again to sand preparation plant in foundries.

In metallurgy, chemical industry, cement, paper, sugar and fertilizer industries, there are conveyors which provide constant delivery of raw materials to factories and provide material delivery to furnaces located in these places, in another words they work with the effect of temperature.

## **RUBBER BELT FEATURES AND STRUCTURE**

In addition to delivery of the material, belt should resist against pulling force which is necessary for movement, mechanical and erosional effect of material, humidity and heat. Belt is also exposed to impacts, centrifuge power and bending due to reclining of rollers and clinging to pulleys in the loading site of the material. For a proper work, a conveyor belt should have the following features:

- Low humidity absorption
- High durability
- Low specific weight
- Low extension
- Durability against effects caused due to drum clinging and grooving
- Durability against alternative voltages caused by camber changes
- Durability against erosive effect of materials and long-lasting

Rubber belts which provide endurance in middle section with made by synthetic materials like cotton or nylon, have coating with several layers are being found a wide application area since they fulfill the above mentioned conditions. Midst, upper, bottom and side of the coating layers in belts are coated with rubber.

## ROLLERS (IDLERS)

Service life of conveyor rollers should be at least few years. A few factors determine the service life of rollers: in brief, pressure load (weight of handling material), length of rollers, characteristic feature and type of bearing, sealings and regular maintenance.

**AKKAYALAR CONVEYOR** produces rollers in types and features indicated below according to quality and technical details which customer needs to be used in conveyor system.

### Roller Codes:

To define rollers even better; we explain the series and types according to the standard design for shafts or basic figures which stand for necessary measurements as shown in the table.

### AKRU1,20T1, 89Ce\_\_\_\_, \_323

Code	Explanation
<b>AKRU1</b>	Roller Type
<b>20</b>	Shaft diameter
<b>T1*</b>	Shaft wrench
<b>_</b>	Special shaft design
<b>89</b>	Pipe diameter
<b>Ce</b>	Pipe type
<b>_____</b>	Special pipe design
<b>_323</b>	Distance between wrench depths

### PIPE TYPE CODES

BASIC	COMPLEMENTARY	EXPLANATION
<b>Ce</b>		Steel St 37 (DIN 17100) (EN 10219-1)
<b>Al</b>		Stainless Steel AISI 304
<b>Sp</b>		Steel Rod Helix Convolution
<b>Ga</b>		Galvanized Pipe
<b>Po</b>		Polyamide Pipe
	<b>Bo</b>	Electro Static Paint
	<b>RD</b>	Impact Roller
	<b>RR</b>	Return Roller with return Disc
	<b>DD</b>	Return Roller with Impact/Impact Disc
	<b>DR</b>	Return Roller with Impact/Return Disc
	<b>RV</b>	Double Group return Roller with Impact/Return Disc
	<b>RH</b>	Cleaning Roller with Helix Disc
	<b>Pu</b>	Polyurethane Coated Roller
	<b>Ka</b>	Rubber Coated Roller

**PIPE;** We use welded type pipe, St-37,2 quality, suitable for DIN 2458 and EN 10219 norms. Pipe diameters we mostly use are  $\varnothing$  60, 63, 76, 89, 102, 108, 114, 127, 133, 139, 159 mm and Wall thickness of pipe is between 3 and 9 mm.

**BEARING:** Bearing from TS 6269 C3 series, not requiring maintenance, self- lubricated and resistant against dust at both sides.

**BEARING HOUSING;** manufactured from cold deep drawing in our firm from HRP A1 quality sheet metal, product of Ereğli, wall thickness between 3-5 mm, resistant to heavy service and may be welded. Housings are merged pipes automatically and at both sides circumferentially at the same time.

**SHAFT;** material Ç1040, Ç1050, Ç1010 quality, cold deep drawing all along, J6 sensitive tolerance type sizes are  $\varnothing$ 20, 25, 30, 35, 40 mm.

## SHAFT WRENCH MANUFACTURING TYPES

T1	Straight Wrench			
d	20	25	30	40
SW	14	18	22	32
e	4	4	4	4
g	9	12	12	12
f	13	16	16	16

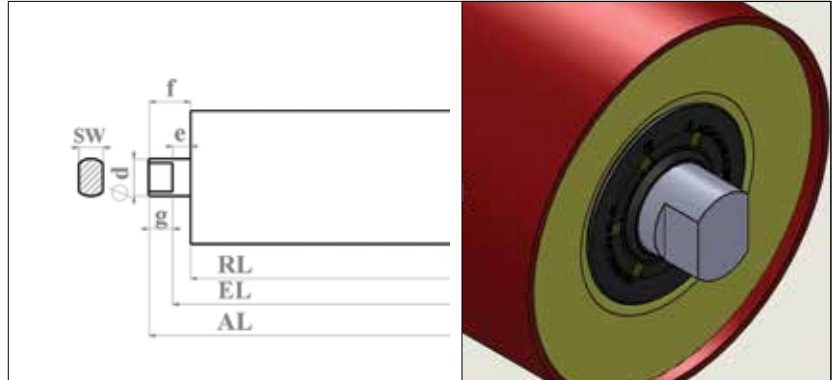

T2	Closed Channel			
d	20	25	30	40
SW	14	18	22	32
e	4	4	4	4
g	9	12	12	12
u	4	4	4	4
f	17	20	20	20

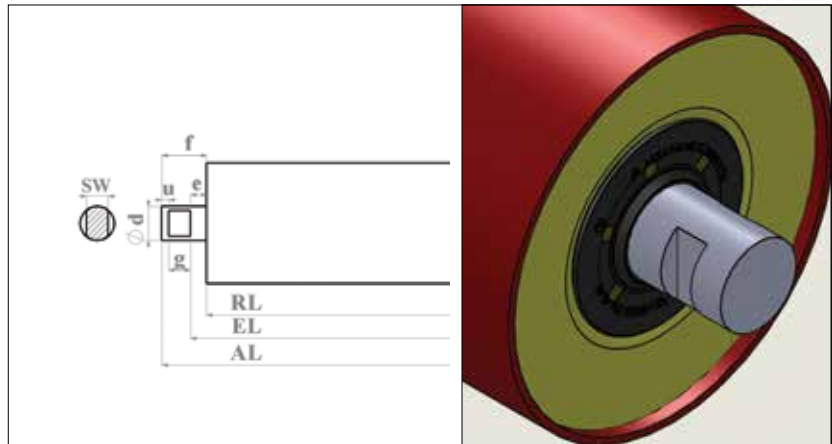

T3	Hole on Shaft			
d	20	25	30	40
u	10	12	16	16
f	24	28	36	38
$\varnothing$	8	10	14	16



T4	Treaded		
d	20	25	30
e	8	8	8
m	35	35	40
f	43	43	48
M	16	20	24

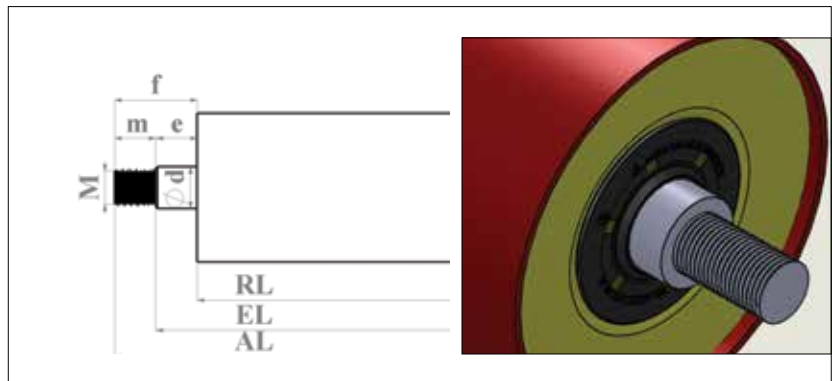

T5	Inside Threaded			
d	20	25	30	40
d <sub>1</sub>	20	25	30	40
f	13	16	16	16
m	20	25	25	25
M	12	16	16	16

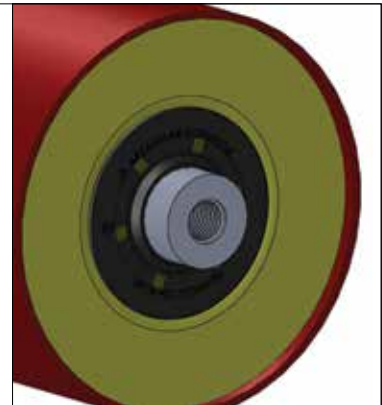
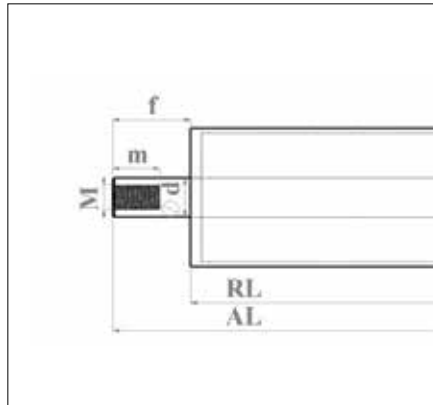

T6	Straight Shaft			
d	20	25	30	40
f	13	13	16	16

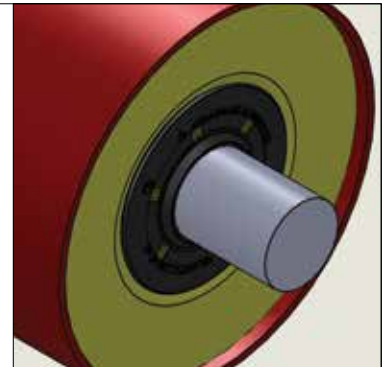
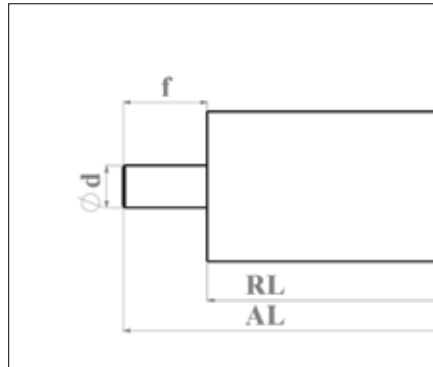

T7	AA Upsizing Roller Adaptors	
d	20	25
SW	30	30
d1	40	40
e	4	4
g	9	11
f	13	15

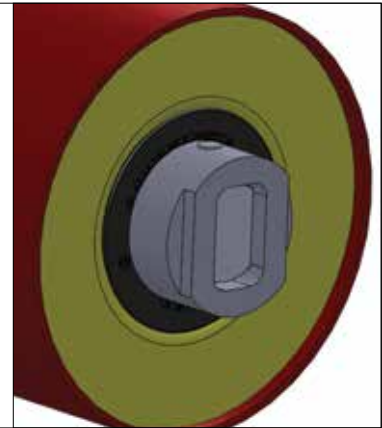
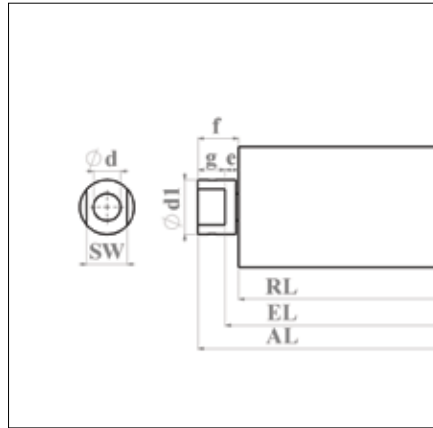

## Pulley / Roller Diameters.

There are factors which determine working conditions, band width and roller diameter. Roller diameter changes depending on the pipe diameter it is built in. Bigger roller diameter is beneficial in terms of band life since it will increase band camber radius. However, bigger diameter pipe will increase the cost.

### MATERIAL FEATURES:

Sealing: Water and dust resistant sealing is made of material 1mm steel sheet which is coated with nitrile rubber as double lipped tightness feature with 100% permeability is patented to our firm. Also, 150-180°C heat resistant type polyamide-6 is used in multi-channel labyrinths.



### ROLLER PIPE CORROSION PROTECTION;

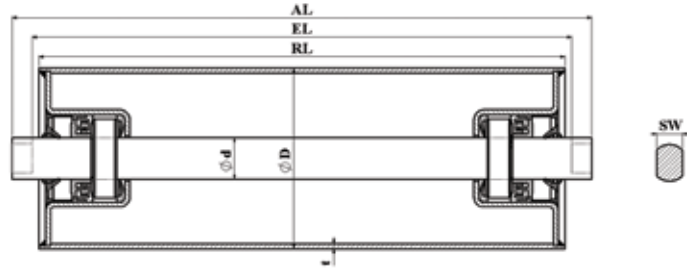

Our rollers are painted in thickness of 60-90 micrometer with electrostatic powder paint against corrosion. If requested, electro-galvanized, Polyurethane Coating, rubber lagging rollers are also available.









D Ø60 - Ø63Ce	AKRU1	AKRU2	AKRU3
d Ø Shaft	20	22/20	25
Bearing	6204	6204	6205
SW Switch Wrench	14	14	18
t Pipe Wall Thickness	3 mm	3 mm	3 mm

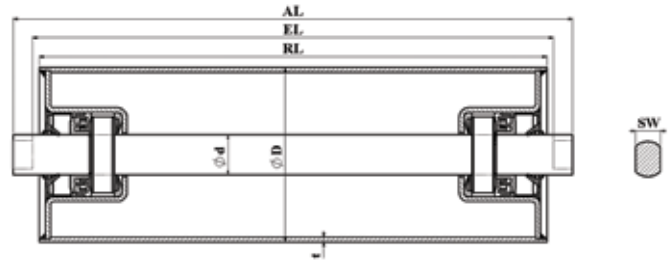

Norm: DIN 22212 - 2			BELT WIDTH			Weight (Kg)		
RL	EL	AL				AKRU1	AKRU2	AKRU3
165	173	191	400	•	•	1,8	1,9	2,2
200	208	226	500	300	•	2,1	2,2	2,5
250	258	276	650	400	•	2,4	2,6	2,9
315	323	341	800	500	•	3,1	3,3	3,7
380	388	406/412	1000	650	300	3,3	3,6	4,0
465	473	491	1200	800	•	3,9	4,2	4,7
500	508	532	•	•	400	4,2	4,4	5,0
600	608	632	•	•	500	4,9	5,2	5,8
750	758	782	•	•	650	5,9	6,3	7,1
950	958	982	•	•	800	7,3	7,8	8,7
1150	1158	1182	•	•	1000	8,7	9,3	10,4
1400	1408	1432	•	•	1200	10,4	11,1	12,4

Norm: NFE 53300			BELT WIDTH			Weight (Kg)		
RL	EL	AL				AKRU1	AKRU2	AKRU3
150	156	176	400	•	•	1,7	1,8	2,1
190	196	216	500	300	•	2,0	2,1	2,4
240	246	266	650	400	•	2,4	2,5	2,8
290	296	316	800	500	•	2,9	3,2	3,6
360	366	386	1000	650	300	3,3	3,5	3,9
430	436	456	1200	800	•	3,7	3,9	4,4
475	508	540	•	•	400	4,1	4,4	4,9
575	608	640	•	•	500	4,8	5,1	5,7
725	758	790	•	•	650	5,8	6,2	7,0
875	908	940	•	•	800	6,8	7,3	8,2
1115	1148	1190	•	•	1000	8,5	9,1	10,2
1315	1348	1380	•	•	1200	9,9	10,6	11,9





DØ 89 Ce	AKRU1	AKRU2	AKRU3	AKRU4	AKRU5	AKRU6
d Ø Shaft	20	22/20	25	26/25	30	32/30
Bearing	6204	6204	6205	6305	6206	6306
SW Switch Wrnech	14	14	18	18	22	22
t Pipe Wall Thikcnss	3 mm	3 mm	3 mm	3 mm	3 mm	3 mm

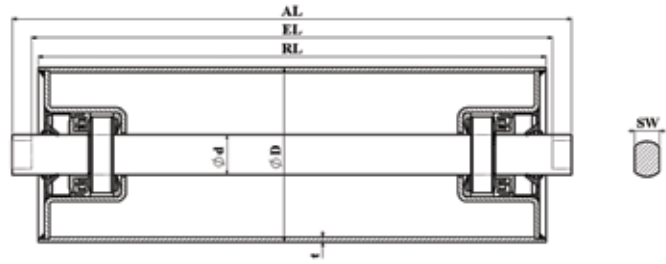

Norm: DIN 22212 - 2			BELT WIDTH			Weight (Kg)					
RL	EL	AL				AKRU 1	AKRU 2	AKRU 3	AKRU 4	AKRU 5	AKRU 6
200	208	226	500	300	•	2,7	2,9	3,1	3,5	3,8	4,4
250	258	276	650	400	•	3,2	3,3	3,6	4,0	4,4	5,0
315	323	341	800	500	•	3,8	3,9	4,3	4,7	5,1	5,9
380	388	406/412	1000	650	300	4,3	4,6	5,0	5,4	6,0	6,7
465	473	491	1200	800	•	5,1	5,3	5,8	6,3	6,9	7,8
500	508	532	•	•	400	5,4	5,7	6,2	6,7	7,4	8,2
530	538	562	1400	•	•	5,6	5,9	6,5	7,0	7,8	8,6
600	608	632	•	1000	500	6,3	6,6	7,2	7,7	8,6	9,5
700	708	726	•	1200	•	7,1	7,5	8,2	8,8	9,7	10,7
750	758	782	•	•	650	7,6	8,0	8,8	9,3	10,4	11,4
800	808	832	•	1400	•	8,0	8,5	9,3	9,8	11,0	12,0
950	958	982	•	•	800	9,4	9,9	10,8	11,4	12,7	13,9
1150	1158	1182	•	•	1000	11,1	11,8	12,8	13,5	15,1	16,5
1400	1408	1432	•	•	1200	13,3	14,1	15,4	16,2	18,1	19,6
1600	1608	1632	•	•	1400	15,1	16,0	17,4	18,3	20,5	22,2

Norm: NFE 53300			BELT WIDTH			Weight (Kg)					
RL	EL	AL				AKRU 1	AKRU 2	AKRU 3	AKRU 4	AKRU 5	AKRU 6
190	196	216	500	300	•	2,6	2,8	3,0	3,4	3,7	4,3
240	246	266	650	400	•	3,1	3,2	3,5	3,9	4,3	4,9
290	296	316	800	500	•	3,5	3,7	4,0	4,5	4,8	5,5
360	366	386	1000	650	300	4,1	4,4	4,8	5,2	5,7	6,4
430	436	456	1200	800	•	4,8	5,0	5,5	5,9	6,5	7,3
475	508	540	•	•	400	5,3	5,5	6,1	6,6	7,3	8,1
500	506	526	1400	•	•	5,4	5,7	6,2	6,7	7,4	8,2
675	608	640	•	1000	500	6,8	7,1	7,7	8,3	9,1	10,0
725	758	790	•	•	650	7,5	7,9	8,6	9,2	10,2	11,3
775	781	801	•	1400	•	7,8	8,2	9,0	9,6	10,6	11,7
875	908	940	•	•	800	8,8	9,3	10,2	10,8	12,0	13,2
1115	1148	1180	•	•	1000	10,9	11,5	12,6	13,3	14,9	16,2
1315	1348	1380	•	•	1200	12,7	13,4	14,7	15,4	17,3	18,8
1515	1548	1580	•	•	1400	14,4	15,3	16,7	17,5	19,6	21,3





D Ø 108 Ce	AKRU1	AKRU2	AKRU3	AKRU4	AKRU5	AKRU6	AKRU7
d Ø Shaft	20	22/20	25	26/25	30	32/30	40
Bearing	6204	6204	6205	6305	6206	6306	6308
SW Switch Wrnech	14	14	18	18	22	22	32
t Pipe Wall Thickness	3 mm	3 mm	3 mm	3 mm	3 mm	3 mm	4 mm

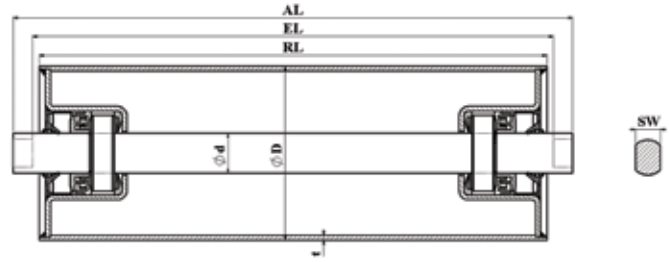

Norm: DIN 22212 - 2			BELT WIDTH			Weight (Kg)						
RL	EL	AL				AKRU 1	AKRU 2	AKRU 3	AKRU 4	AKRU 5	AKRU 6	AKRU 7
250	258	276	650	400	•	3,7	3,8	4,2	4,6	4,9	5,5	8,4
315	323	341	800	500	•	4,3	4,5	4,9	5,3	5,8	6,5	9,5
380	388	406	1000	650	300	5,0	5,2	5,7	6,1	6,6	7,4	10,7
465	473	491	1200	800	•	5,9	6,1	6,7	7,1	7,8	8,6	12,2
500	508	532	•	•	400	6,3	6,5	7,1	7,6	8,3	9,1	12,8
530	538	562	1400	•	•	6,5	6,8	7,4	7,9	8,6	9,5	13,3
600	608	626/632	1600	1000	500	7,3	7,6	8,3	8,8	9,6	10,5	14,6
700	708	726	•	1200	•	8,3	8,7	9,4	9,9	10,9	11,9	16,3
750	758	782	•	•	650	8,8	9,2	10,0	10,6	11,6	12,6	17,2
800	808	832	•	1400	•	9,3	9,8	10,6	11,1	12,2	13,3	18,1
900	908	932	•	1600	•	10,3	10,8	11,7	12,3	13,6	14,7	19,9
950	958	982	•	•	800	10,9	11,4	12,3	12,9	14,2	15,4	20,8
1150	1158	1182	•	2000	1000	12,9	13,5	14,6	15,3	16,9	18,2	24,3
1400	1408	1432	•	•	1200	15,5	16,2	17,6	18,3	20,2	21,8	28,7
1600	1608	1632	•	•	1400	17,5	18,4	19,9	20,7	22,9	24,6	32,2
1800	1808	1832	•	•	1600	19,6	20,5	22,2	23,1	25,6	27,4	35,7

Norm: NFE 53300			BELT WIDTH			Weight (Kg)						
RL	EL	AL				AKRU 1	AKRU 2	AKRU 3	AKRU 4	AKRU 5	AKRU 6	AKRU 7
240	246	266	650	400	•	3,6	3,7	4,1	4,4	4,8	5,4	8,2
290	296	316	800	500	•	4,1	4,3	4,6	5,0	5,4	6,1	9,1
360	366	386	1000	650	300	4,8	5,0	5,4	5,9	6,4	7,1	10,3
430	436	456	1200	800	•	5,5	5,8	6,3	6,7	7,3	8,1	11,5
475	508	540	•	•	400	6,1	6,4	6,9	7,4	8,1	9,0	12,7
500	506	526	1400	•	•	6,2	6,5	7,1	7,5	8,2	9,1	12,8
570	576	596	1600	1000	•	7,0	7,3	7,9	8,4	9,2	10,0	14,0
575	608	640	•	•	500	7,1	7,4	8,1	8,6	9,4	10,4	14,5
725	758	790	•	•	650	8,6	9,1	9,8	10,4	11,4	12,5	17,1
875	908	940	•	•	800	10,2	10,7	11,6	12,2	13,4	14,6	19,8
1115	1148	1180	•	•	1000	12,6	13,2	14,4	15,0	16,6	18,0	24,0
1315	1348	1380	•	•	1200	14,7	15,4	16,7	17,4	19,3	20,8	27,5
1515	1548	1580	•	•	1400	16,7	17,5	19,0	19,8	21,9	23,6	31,0
1715	1748	1780	•	•	1600	18,8	19,7	21,3	22,2	24,6	26,4	34,6





D Ø 133 Ce	AKRU1	AKRU2	AKRU3	AKRU4	AKRU5	AKRU6	AKRU7
d Ø Shaft	20	22/20	25	26/25	30	32/30	40
Bearing	6204	6204	6205	6305	6206	6306	6308
SW Switch Wrnech	14	14	18	18	22	22	32
t Pipe Wall Thickness	4 mm	4 mm	4 mm	4 mm	4 mm	4 mm	4 mm

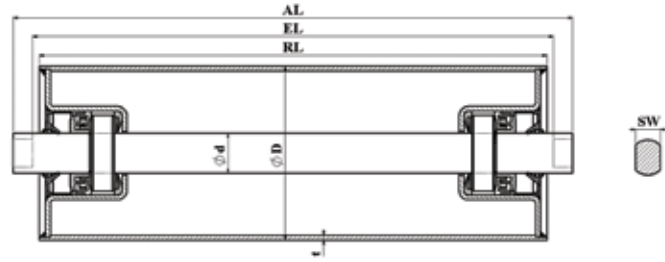

Norm: DIN 22212 - 2			BELT WIDTH			Weight (Kg)						
RL	EL	AL				AKRU 1	AKRU 2	AKRU 3	AKRU 4	AKRU 5	AKRU 6	AKRU 7
315	323	341	800	•	•	6,2	6,4	6,8	7,2	7,7	8,4	11,5
380	388	406	1000	650	•	7,2	7,4	7,9	8,3	8,8	9,6	13,0
465	473	491	1200	800	•	8,4	8,7	9,3	9,8	10,4	11,2	14,9
530	538	562	1400	•	•	9,4	9,7	10,4	10,9	11,6	12,5	16,4
600	608	626/632	1600	1000	•	10,5	10,8	11,5	12,1	12,9	13,8	18,0
670	678	702	1800	•	•	11,4	11,7	12,4	13,0	13,8	14,7	18,9
700	708	726	•	1200	•	12,0	12,4	13,2	13,7	14,7	15,7	20,2
750	758	776/782	2000	•	650	12,8	13,2	14,0	14,6	15,7	16,7	21,4
800	808	832	2200	1400	•	13,5	14,0	14,9	15,4	16,5	17,7	22,5
900	908	932	2400	1600	•	15,1	15,6	16,5	17,1	18,4	19,6	24,8
950	958	982	2600	•	800	15,8	16,3	17,3	18,0	19,3	20,5	25,9
1150	1158	1182	•	2000	1000	18,9	19,5	20,7	21,3	22,9	24,3	30,4
1400	1408	1432	•	•	1200	22,7	23,4	24,8	25,6	27,5	29,1	36,1
1600	1608	1632	•	•	1400	25,7	26,5	28,1	28,9	31,2	32,9	40,6
1800	1808	1832	•	2400	1600	28,7	29,7	31,4	32,3	34,8	36,7	45,1

Norm: NFE 53300			BELT WIDTH			Weight (Kg)						
RL	EL	AL				AKRU 1	AKRU 2	AKRU 3	AKRU 4	AKRU 5	AKRU 6	AKRU 7
290	296	316	800	•	•	5,8	6,0	6,4	6,8	7,2	7,9	11,0
355	366	386	1000	650	•	6,8	7,0	7,5	7,9	8,4	9,2	12,5
425	436	456	1200	800	•	7,9	8,1	8,6	9,1	9,7	10,5	14,1
495	506	526	1400	•	•	8,9	9,2	9,8	10,3	11,0	11,8	15,6
565	576	596	1600	1000	•	10,0	10,3	11,0	11,5	12,2	13,2	17,2
635	646	666	1800	•	•	11,0	11,4	12,1	12,6	13,5	14,5	18,8
575	608	640	•	•	500	10,2	10,5	11,3	11,8	12,7	13,6	17,8
725	758	790	2000	•	650	12,5	12,9	13,7	14,3	15,4	16,4	21,2
875	908	940	•	•	800	14,8	15,3	16,2	16,8	18,1	19,3	24,6
1115	1148	1180	•	•	1000	18,4	19,0	20,2	20,9	22,5	23,9	30,0
1315	1348	1380	•	•	1200	21,4	22,2	23,5	24,3	26,1	27,7	34,5
1515	1548	1580	•	•	1400	24,5	25,3	26,8	27,6	29,8	31,5	39,0
1715	1748	1780	•	•	1600	27,5	28,4	30,1	31,0	33,4	35,3	43,5



D Ø 159 Ce	AKRU1	AKRU2	AKRU3	AKRU4	AKRU5	AKRU6	AKRU7
d Ø Shaft	20	22/20	25	26/25	30	32/30	40
Bearing	6204	6204	6205	6305	6206	6306	6308
SW Switch Wreneh	14	14	18	18	22	22	32
t Pipe Wall Thickness	4 mm	4 mm	4 mm	4 mm	4 mm	5 mm	5 mm

Norm: DIN 22212 - 2			BELT WIDTH			Weight (Kg)						
RL	EL	AL				AKRU 1	AKRU 2	AKRU 3	AKRU 4	AKRU 5	AKRU 6	AKRU 7
315	323	341	800	•	•	7,2	7,4	7,8	8,3	8,7	9,4	12,8
380	388	406	1000	•	•	8,4	8,6	9,0	9,5	10,1	10,8	14,4
465	473	491	1200	•	•	9,9	10,1	10,7	11,2	11,8	12,6	16,5
530	538	562	1400	•	•	11,0	11,3	11,9	12,5	13,2	14,0	18,2
600	608	626/632	1600	•	•	12,3	12,6	13,3	13,8	14,7	15,6	20,0
670	678	702	1800	•	•	13,5	13,9	14,6	15,2	16,1	17,0	21,7
750	758	776/782	2000	•	•	14,9	15,4	16,1	16,8	17,9	18,8	23,8
800	808	832	2200	•	•	15,8	16,3	17,1	17,7	18,8	19,9	25,0
900	908	932	2400	•	•	17,6	18,1	19,0	19,7	20,9	22,1	27,5
950	958	982	2600	•	800	18,5	19,0	20,0	20,7	22,0	23,1	28,8
1050	1058	1082	2800	•	•	20,3	20,8	21,9	22,6	24,0	25,3	31,3
1120	1128	1152	3000	•	•	21,5	22,1	23,2	24,0	25,5	26,8	33,1
1150	1158	1182	•	2000	1000	22,0	22,7	23,8	24,5	26,1	27,4	33,8
1400	1408	1432	•	•	1200	26,5	27,2	28,6	29,4	31,3	32,8	40,1
1600	1608	1632	•	•	1400	30,0	30,9	32,4	33,3	35,5	37,2	45,1
1800	1808	1832	•	2400	1600	33,6	34,5	36,2	37,2	39,7	41,5	50,2
2000	2008	2032	•	•	1800	37,1	38,2	40,1	41,1	43,8	45,8	55,2
2200	2208	2232	• •	•	2000	40,7	41,8	43,9	45,0	48,0	50,1	60,2

Norm: NFE 53300			BELT WIDTH			Weight (Kg)						
RL	EL	AL				AKRU 1	AKRU 2	AKRU 3	AKRU 4	AKRU 5	AKRU 6	AKRU 7
290	296	316	800	•	•	6,8	6,9	7,3	7,8	8,2	8,8	12,1
355	366	386	1000	•	•	7,9	8,1	8,6	9,1	9,6	10,3	13,8
425	436	456	1200	•	•	9,2	9,4	9,9	10,4	11,0	11,8	15,6
495	506	526	1400	•	•	10,4	10,7	11,3	11,8	12,5	13,3	17,3
565	576	596	1600	•	•	11,7	12,1	12,7	13,3	14,1	15,0	19,4
635	646	666	1800	•	•	12,9	13,3	13,9	14,5	15,4	16,3	20,9
725	758	790	2000	•	650	14,6	15,0	15,8	16,4	17,5	18,5	23,5
875	908	940	•	•	800	17,2	17,7	18,7	19,3	20,6	21,7	27,2
1115	1148	1180	•	•	1000	21,5	22,1	23,2	24,0	25,6	26,9	33,3
1315	1348	1380	•	•	1200	25,1	25,8	27,1	27,9	29,7	31,2	38,3
1515	1548	1580	•	•	1400	28,6	29,4	30,9	31,8	33,9	35,5	43,3
1715	1748	1780	•	•	1600	32,2	33,1	34,7	35,7	38,1	39,9	48,3

## IMPACT ROLLERS

Impact rollers are comprised of a belt roller which main body is steel, rubber impact rings absorbing shock in various dimensions, fixed with support rings in order to prevent slide of's from edges. Impact rollers are normally being used for absorbing loads in the sections corresponding to bottom of return and increasing of protection against damage and breakdown occurred in the material transported. Carrying roller should be suitable with its diameter so that it does not make fluctuation on belt. It is manufactured fitting tight on steel roller through a special machine. They are fitted collaterally along roller. Discs are manufactured, pressing in suitable moulds by black rubber, in hardness of 65 ±5 Shore A in accordance to DIN 53479 norm.

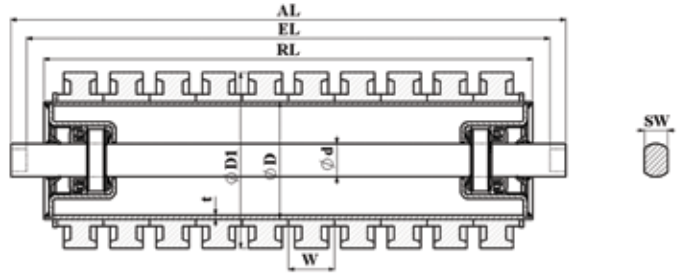
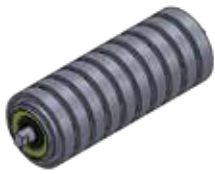

AKRD Impact Idler Norm DIN 22112-2		B	400	500	650	800	1000	1200	1400	1600	1800
		RL	165	200	250	315	380	465	530	600	670
		EL	173	208	258	323	388	473	538	608	678
		AL	191	226	276	341	406	491	562	626/632	702
Disc Dimensions	Ø D	Ø D1	Rubber Disc Quantities								
60x89x35	60	89	4	5	7	8	10	13	•	•	•
60x108x35	60	108	4	5	7	8	10	13	•	•	•
60x114x35	60	114	4	5	7	8	10	13	•	•	•
60x120x35	60	120	4	5	7	8	10	13	•	•	•
60x133x35	60	133	4	5	7	8	10	13	•	•	•
89x114x35	89	114	4	5	7	8	10	13	14	•	•
89x133x35	89	133	4	5	7	8	10	13	14	•	•
89x159x35	89	159	4	5	7	8	10	13	14	•	•
108x159x35	108	159	•	•	7	8	10	13	14	16	18

	AKRD1	AKRD2	AKRD3	AKRD4	AKRD5	AKRD6	AKRD7
Ø Shaft	20	22/20	25	26/25	30	32/30	40
Bearing	6204	6204	6205	6305	6206	6306	6308
AA (SW)	14	14	18	18	22	22	32

AKRD Impact Idler Norm NFE-53300		B	400	500	650	800	1000	1200	1400	1600	1800
		RL	150	190	240	290	360	430	500	570	640
		EL	156	196	246	296	366	436	506	576	646
		AL	176	216	266	316	386	456	526	596	666
Disc Dimensions	Ø D	Ø D1	Rubber Disc Quantities:								
60x89x35	60	89	4	5	6	8	10	12	•	•	•
60x108x35	60	108	4	5	6	8	10	12	•	•	•
60x114x35	60	114	4	5	6	8	10	12	•	•	•
60x120x35	60	120	4	5	6	8	10	12	•	•	•
60x133x35	60	133	4	5	6	8	10	12	•	•	•
89x114x35	89	114	4	5	6	8	10	12	13	•	•
89x133x35	89	133	4	5	6	8	10	12	13	•	•
89x159x35	89	159	4	5	6	8	10	12	13	•	•
108x159x35	108	159	•	•	6	8	10	12	13	16	18

## LOWER RETURN ROLLERS WITH DISCS

Smooth moving of belt may be affected from type of material transported especially if this material is adhesive and so can easily adhere on belt surface. In this situation, material residues will be on return rollers which support belt and this will give rise to accumulation of irregular material on roller. As a result of that, it will lead not only to abrasion and damage of belt, but also diversion of normal track way of belt. Return rollers plays very important role in prevention of material accumulation which takes place in some situations on belt surface. In normal circumstances, with sharp edge placed at intervals are available in centre part of roller and in the area which breaks material accumulation into pieces found in centre of belt. Return rollers should not be used as belt tensioning elements.

**AKSR Sequence with Return Disc**



**AKRR Return/ Return Disc Sequence**



**AKDD Sequence with Impact and Impact Disc**

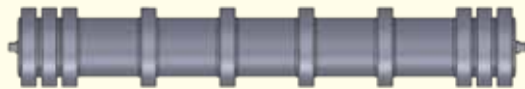

**AKRH Sequence with Helix Disc**



**AKDR Sequence with Impact and Return Discs**

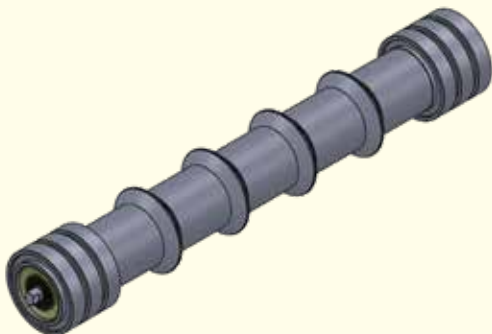

**AKRV Sequence with Double Group V-Return Rollers**

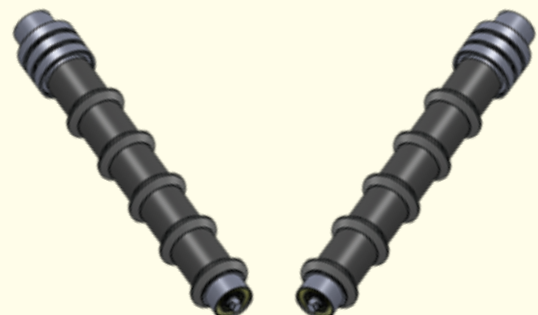

## AKSR Sequence with Return Disc

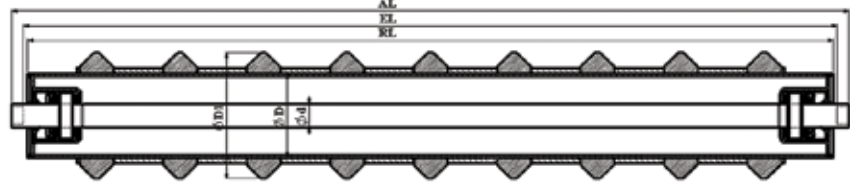

	AKSR1	AKSR2	AKSR3	AKSR4	AKSR5	AKSR6	AKSR7
d Ø Shaft	20	22/20	25	26/25	30	32/30	40
Bearing	6204	6204	6205	6305	6206	6306	6308
AA (SW)	14	14	18	18	22	22	32

Belt Width B	Steel Pipe ØD	Rubber Outer Diameter ØD1	Rubber disc dimensions mm	Spacer bushing dimensions mm	Norm DIN 22112-2			Norm NFE53300		
					Disc Quantity	Spacer bushing quantity	RL mm	Disc Quantity	Spacer bushing quantity	RL mm
400	60	89	60*89*35	60*70*50	6	5	500	6	5	475
		108	60*108*35	60*70*50	6	5		6	5	
		133	60*133*35	60*70*50	6	5		6	5	
500	60	89	60*89*35	60*70*50	7	6	600	7	6	575
		108	60*108*35	60*70*50	7	6		7	6	
		133	60*133*35	60*70*50	7	6		7	6	
	89	133	89*133*35	89*100*50	7	6	7	6		
650	60	89	60*89*35	60*70*75	7	6	750	7	6	725
		108	60*108*35	60*70*75	7	6		7	6	
		133	60*133*35	60*70*75	7	6		7	6	
	89	133	89*133*35	89*100*75	7	6	7	6		
		159	89*159*35	89*100*75	7	6	7	6		
800	60	89	60*89*35	60*70*75	9	8	950	8	7	875
		108	60*108*35	60*70*75	9	8		8	7	
		133	60*133*35	60*70*75	9	8		8	7	
	89	133	89*133*35	89*100*75	9	8	8	7		
		159	89*159*35	89*100*75	9	8	8	7		
		108	159	108*159*35	108*120*75	9	8	8	7	
1000	60	108	60*108*35	60*70*75	11	10	1150	10	9	1115
		133	60*133*35	60*70*75	11	10		10	9	
	89	133	89*133*35	89*100*75	11	10		10	9	
		159	89*159*35	89*100*75	11	10		10	9	
	108	159	108*159*35	108*120*75	11	10		10	9	
1200	60	108	60*108*35	60*70*75	13	12	1400	12	11	1315
		133	60*133*35	60*70*75	13	12		12	11	
	89	133	89*133*35	89*100*75	13	12		12	11	
		159	89*159*35	89*100*75	13	12		12	11	
		108	159	108*159*35	108*120*75	13		12	12	

### AKSR Sequence with return Disc

Pointed return type discs are placed with intervals through the pipe. To provide discs from shifting, they are supported to each other with polyamide spacer bushings.



## AKRR Return/ Return Disc Sequence

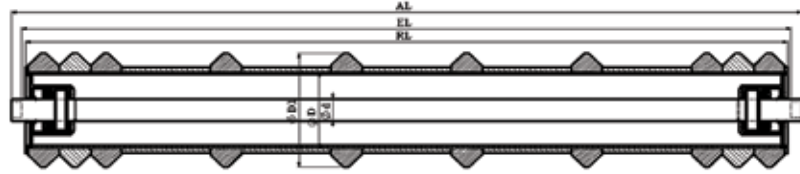

	AKRR1	AKRR2	AKRR3	AKRR4	AKRR5	AKRR6	AKRR7
Ø Shaft	20	22/20	25	26/25	30	32/30	40
Bearing	6204	6204	6205	6305	6206	6306	6308
AA (SW)	14	14	18	18	22	22	32

Belt Width B	Steel Pipe ØD	Rubber Outer Diameter ØD1	Rubber disc dimensions mm	Spacer bushing dimensions mm	Norm DIN 22112-2			Norm NFE53300		
					Disc Quantity	Spacer bushing quantity	RL mm	Disc Quantity	Spacer bushing quantity	RL mm
500	60	89	60*89*35	60*70*60	3+3+3	4	600	3+3+3	4	575
		108	60*108*35	60*70*60	3+3+3	4		3+3+3	4	
		133	60*133*35	60*70*60	3+3+3	4		3+3+3	4	
	89	133	89*133*35	89*100*60	3+3+3	4	3+3+3	4		
650	60	89	60*89*35	60*70*75	3+4+3	5	750	3+4+3	5	725
		108	60*108*35	60*70*75	3+4+3	5		3+4+3	5	
		133	60*133*35	60*70*75	3+4+3	5		3+4+3	5	
	89	133	89*133*35	89*100*75	3+4+3	5	3+4+3	5		
		159	89*159*35	89*100*75	3+4+3	5	3+4+3	5		
800	60	89	60*89*35	60*70*75	3+6+3	7	950	3+5+3	6	875
		108	60*108*35	60*70*75	3+6+3	7		3+5+3	6	
		133	60*133*35	60*70*75	3+6+3	7		3+5+3	6	
	89	133	89*133*35	89*100*75	3+6+3	7	3+5+3	6		
		159	89*159*35	89*100*75	3+6+3	7	3+5+3	6		
	108	159	108*159*35	108*120*75	3+6+3	7	3+5+3	6		
1000	60	108	60*108*35	60*70*75	4+7+4	8	1150	4+7+4	8	1115
		133	60*133*35	60*70*75	4+7+4	8		4+7+4	8	
	89	133	89*133*35	89*100*75	4+7+4	8		4+7+4	8	
		159	89*159*35	89*100*75	4+7+4	8		4+7+4	8	
	108	159	108*159*35	108*120*75	4+7+4	8		4+7+4	8	
1200	60	108	60*108*35	60*70*75	4+8+4	9	1400	4+8+4	9	1315
		133	60*133*35	60*70*75	4+8+4	9		4+8+4	9	
	89	133	89*133*35	89*100*75	4+8+4	9		4+8+4	9	
		159	89*159*35	89*100*75	4+8+4	9		4+8+4	9	
	108	159	108*159*35	108*120*75	4+8+4	9		4+8+4	9	

### AKRR Return/ Return Disc Sequence

Pointed return type discs are placed with intervals in central area and with groups in edge areas. To provide discs from shifting, they are supported to each other with polyamide spacer bushes.

## AKDD Sequence with Impact and Impact Disc

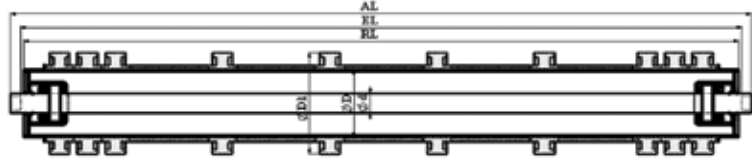

	AKDD1	AKDD2	AKDD3	AKDD4	AKDD5	AKDD6	AKDD7
d Ø Shaft	20	22/20	25	26/25	30	32/30	40
Bearing	6204	6204	6205	6305	6206	6306	6308
AA (SW)	14	14	18	18	22	22	32

Belt Width B	Steel Pipe ØD	Rubber Outer Diameter ØD1	Rubber disc dimensions mm	Spacer bushing dimensions mm	Norm DIN 22112-2			Norm NFE53300		
					Disc Quantity	Spacer bushing quantity	RL mm	Disc Quantity	Spacer bushing quantity	RL mm
650	60	108	60*108*35	60*70*75	3+4+3	5	750	3+4+3	5	725
		133	60*133*35	60*70*75	3+4+3	5		3+4+3	5	
	89	133	89*133*35	89*100*75	3+4+3	5		3+4+3	5	
800	60	108	60*108*35	60*70*75	3+6+3	7	950	3+5+3	6	875
		133	60*133*35	60*70*75	3+6+3	7		3+5+3	6	
	89	133	89*133*35	89*100*75	3+6+3	7		3+5+3	6	
		159	89*159*35	89*100*75	3+6+3	7		3+5+3	6	
1000	60	108	60*108*35	60*70*75	4+7+4	8	1150	4+7+4	8	1115
		133	60*133*35	60*70*75	4+7+4	8		4+7+4	8	
	89	133	89*133*35	89*100*75	4+7+4	8		4+7+4	8	
		159	89*159*35	89*100*75	4+7+4	8		4+7+4	8	
1200	60	108	60*108*35	60*70*75	4+8+4	9	1400	4+8+4	9	1315
		133	60*133*35	60*70*75	4+8+4	9		4+8+4	9	
	89	133	89*133*35	89*100*75	4+8+4	9		4+8+4	9	
		159	89*159*35	89*100*75	4+8+4	9		4+8+4	9	
		108	159	108*159*35	108*120*75	4+8+4		9	4+8+4	
1400	89	133	89*133*35	89*100*100	4+9+4	10	1600	4+8+4	9	1515
		159	89*159*35	89*100*100	4+9+4	10		4+8+4	9	
	108	159	108*159*35	108*120*100	4+9+4	10		4+8+4	9	
1600	89	133	89*133*35	89*100*100	4+10+4	11	1800	4+9+4	11	1715
		159	89*159*35	89*100*100	4+10+4	11		4+9+4	11	
	108	159	108*159*35	108*120*100	4+10+4	11		4+9+4	11	

### AKDD Sequence with Impact and Impact Disc

Impact type discs are placed as adjacent at roller sides, with intervals in central area, and by supporting each with spacer bushings to prevent shifting.

## AKDR Sequence with Impact and Return



	AKDD1	AKDD2	AKDD3	AKDD4	AKDD5	AKDD6	AKDD7
d Ø Shaft	20	22/20	25	26/25	30	32/30	40
Bearing	6204	6204	6205	6305	6206	6306	6308
AA (SW)	14	14	18	18	22	22	32

Belt Width B	Steel Pipe ØD	Rubber Outer Diameter ØD1	Rubber disc dimensions mm	Spacer bushing dimensions mm	Norm DIN 22112-2			Norm NFE53300		
					Disc Quantity	Spacer bushing quantity	RL mm	Disc Quantity	Spacer bushing quantity	RL mm
650	60	108	60*108*35	60*70*75	3+4+3	5	750	3+4+3	5	725
		133	60*133*35	60*70*75	3+4+3	5		3+4+3	5	
	89	133	89*133*35	89*100*75	3+4+3	5		3+4+3	5	
800	60	108	60*108*35	60*70*75	3+6+3	7	950	3+5+3	6	875
		133	60*133*35	60*70*75	3+6+3	7		3+5+3	6	
	89	133	89*133*35	89*100*75	3+6+3	7		3+5+3	6	
		159	89*159*35	89*100*75	3+6+3	7		3+5+3	6	
	108	159	108*159*35	108*120*75	3+6+3	7		3+5+3	6	
1000	60	108	60*108*35	60*70*75	4+7+4	8	1150	4+7+4	8	1115
		133	60*133*35	60*70*75	4+7+4	8		4+7+4	8	
	89	133	89*133*35	89*100*75	4+7+4	8		4+7+4	8	
		159	89*159*35	89*100*75	4+7+4	8		4+7+4	8	
	108	159	108*159*35	108*120*75	4+7+4	8		4+7+4	8	
1200	60	108	60*108*35	60*70*75	4+8+4	9	1400	4+8+4	9	1315
		133	60*133*35	60*70*75	4+8+4	9		4+8+4	9	
	89	133	89*133*35	89*100*75	4+8+4	9		4+8+4	9	
		159	89*159*35	89*100*75	4+8+4	9		4+8+4	9	
	108	159	108*159*35	108*120*75	4+8+4	9		4+8+4	9	
1400	89	133	89*133*35	89*100*100	4+9+4	10	1600	4+8+4	9	1515
		159	89*159*35	89*100*100	4+9+4	10		4+8+4	9	
	108	159	108*159*35	108*120*100	4+9+4	10		4+8+4	9	
1600	89	133	89*133*35	89*100*100	4+10+4	11	1800	4+9+4	11	1715
		159	89*159*35	89*100*100	4+10+4	11		4+9+4	11	
	108	159	108*159*35	108*120*100	4+10+4	11		4+9+4	11	

### Sequence with Impact and Return Discs

Impact types are placed combined at heads of rollers, return type s at intervals in central part region and with spacer bushers in order to hinder slides. They are used in heavy service conditions.

## AKRH Sequence with Helix

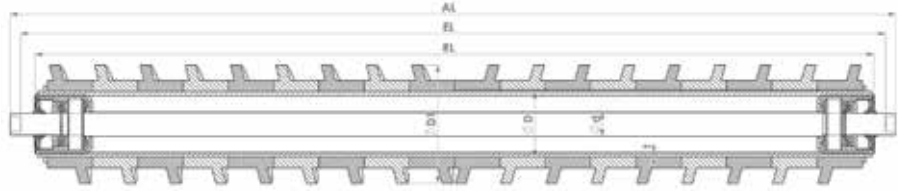

	AKRH1	AKRH2	AKRH3	AKRH4	AKRH5	AKRH6	AKRH7
Ø Shaft	20	22/20	25	26/25	30	32/30	40
Bearing	6204	6204	6205	6305	6206	6306	6308
AA (SW)	14	14	18	18	22	22	32

Belt Width B	Steel Pipe ØD	Outer Diameter ØD1	Disc Dimensions mm	Norm DIN 22112-2				Norm NFE53300			
				Disc Quantity	RL mm	EL mm	AL mm	Disc Quantity	RL mm	EL mm	AL mm
300	60	108	60*108*40	8	380	388	412	8	360	366	386
	89	133	89*133*45	8				8			
400	60	108	60*108*40	12	500	508	526	10	475	508	540
	89	133	89*133*45	10				10			
500	60	108	60*108*40	14	600	608	626	14	575	608	640
	89	133	89*133*45	12				12			
650	60	108	60*108*40	18	750	758	782	18	725	758	790
	89	133	89*133*45	16				16			
	108	159	108*159*40	18				18			
800	60	108	60*108*40	22	950	958	982	20	875	908	940
	89	133	89*133*45	20				18			
	108	159	108*159*40	22				20			
1000	60	108	60*108*40	28	1150	1158	1182	26	1115	1148	1180
	89	133	89*133*45	24				24			
	108	159	108*159*40	28				26			
1200	60	108	60*108*40	34	1400	1408	1432	32	1315	1348	1380
	89	133	89*133*45	30				28			
	108	159	108*159*40	34				32			
1400	60	108	60*108*40	38	1600	1608	1632	36	1515	1548	1580
	89	133	89*133*45	34				32			
	108	159	108*159*40	38				36			
1600	89	133	89*133*45	40	1800	1808	1832	38	1715	1748	1780
	108	159	108*159*40	44				42			

### AKRH Sequence with Helix

It makes return from medium of roller towards its side and cleans material adhered on belt surface. They can be rubber or metal ones.

## AKRV Sequence with Double System

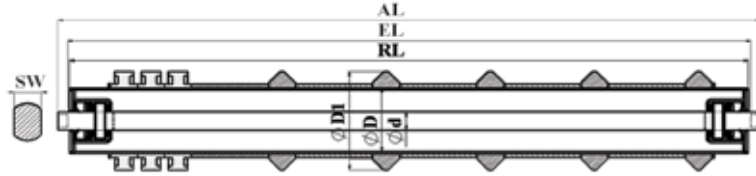

	AKRV1	AKRV2	AKRV3	AKRV4	AKRV5	AKRV6	AKRV7
Ø Shaft	20	22/20	25	26/25	30	32/30	40
Bearing	6204	6204	6205	6305	6206	6306	6308
AA (SW)	14	14	18	18	22	22	32

Belt Width B	Steel Pipe ØD	Rubber Outer Diameter ØD1	Rubber Disc Dimensions mm	Norm DIN 22112-2			Norm NFE53300		
				Impact Type Disc Quantity	Return Type Disc Quantity	RL mm	Impact Type Disc Quantity	Return Type Disc Quantity	RL mm
650	60	108	60*108*35	3	2	380	3	2	355
		133	60*133*35	3	2		3	2	
	89	133	89*133*35	3	2		3	2	
800	60	108	60*108*35	3	3	465	3	3	425
		133	60*133*35	3	3		3	3	
	89	133	89*133*35	3	3		3	3	
		159	89*159*35	3	3		3	3	
1000	60	108	60*108*35	4	4	600	4	4	570
		133	60*133*35	4	4		4	4	
	89	133	89*133*35	4	4		4	4	
		159	89*159*35	4	4		4	4	
1200	60	108	60*108*35	4	4	700			
		133	60*133*35	4	4				
	89	133	89*133*35	4	4				
		159	89*159*35	4	4				
1400	89	133	89*133*35	4	5	800			
		159	89*159*35	4	5				
	108	159	108*159*35	4	5				
1600	89	133	89*133*35	4	6	900			
		159	89*159*35	4	6				
	108	159	108*159*35	4	6				
1800	89	133	89*133*35	4	7	1000			
		159	89*159*35	4	7				
	108	159	108*159*35	4	7				
2000	89	133	89*133*35	4	8	1100			
		159	89*159*35	4	8				
	108	159	108*159*35	4	8				

### AKRV Sequence with Double System

It is thought for V design format chassis sets for double system lower returns. They can be designed in characteristic proportional sizes or desired size in accordance with wide belt conveyors.

## GUIDE ROLLERS

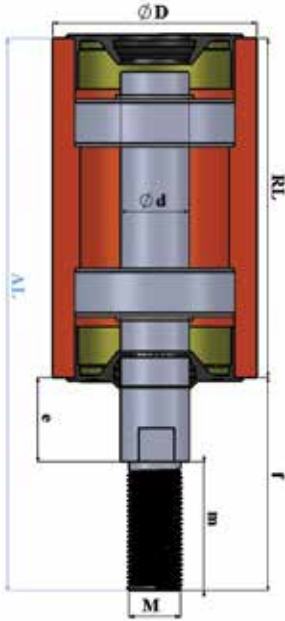

Figure 1: AKRK

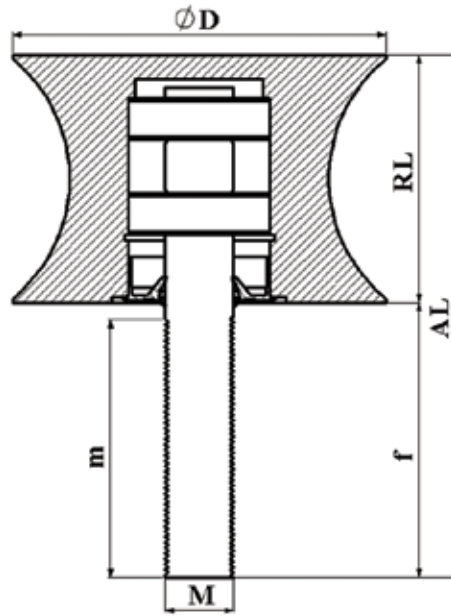

Figure 2: AKEK

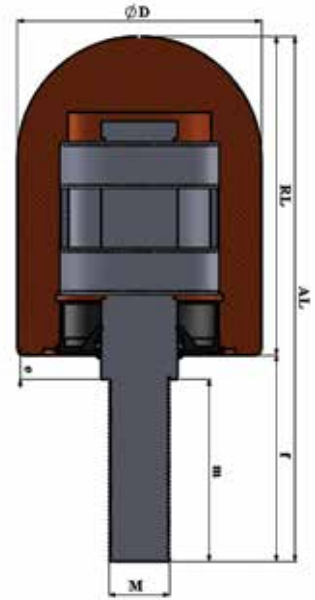

Figure 3: AKOK

D Ø	RL	AL	d Ø	M	m	e	f	t	SW	TYPE	BEARING
60	100	165	20	16	40	10	65	8	17	AKRK1	6204
60	120	185	20	16	40	10	65	8	17	AKRK1	6204
89	100	165	20	16	40	10	65	4	17	AKRK1	6204
89	120	185	20	16	40	10	65	4	17	AKRK1	6204
108	120	185	20	16	40	10	65	4	17	AKRK1	6204
60	100	165	25	20	40	10	65	6	20	AKRK3	6205
60	120	185	25	20	40	10	65	6	20	AKRK3	6205
89	100	165	25	20	40	10	65	4	20	AKRK3	6205
89	120	185	25	20	40	10	65	4	20	AKRK3	6205
108	120	185	25	20	40	10	65	4	20	AKRK3	6205
89	120	185	30	24	40	10	65	4	26	AKRK5	6206
108	120	185	30	24	40	10	65	4	26	AKRK5	6206
137	90	190	25	24	90	10	100			AKEK2	6205
80	105	173	25	20	60	8	68			AKOK2	6205

## AKKA RUBBER COATED ROLLERS

Hot vulcanized coating is being made in the thickness and pattern demanded according to requests and projects of you, our customers. White rubber coating as well as black NBR rubber coating is also made. Polyurethane coated roller in various colours are also produced as per requirements of project.

## AKPO POLYAMIDE, NONCORROSIVE ROLLERS;

In special projects that abrasion, rigidity, resistant to acid and magnetization or in the conveyors with similar properties, rollers made from polyamide or stainless steel material are used. Manufacturing of noncorrosive, polyamide, derlin, polyethylene and cestamide belt pulleys are made by us in suitable sizes according to your project and request.

## AKZI CHAIN DRIVEN BELT ROLLER:

We manufacture pulleys connecting and moving threads with chains fitted as one-sided or two-sided to sides of belt pulleys in accordance with the projects of you, our customers. Manufacturing is executed in various diameters and thread sizes. In the conveyors that roller threads are connected via chains, if offset are available between roller threads, in this case it is possible to mention serious design and manufacturing problems till rupture of chains. Therefore, it should be considered that roller threads are on the same axis. Thread manufacturing of these rollers is important particularly. It should be sensitive on selection of right material, eligible surface treatments and enough hardness value.

## RESISTANT ROLLERS TO THE ACIDIC ENVIRONMENT:

The rollers, resistant to the acidic environment (sugar, fertilizer, cement factories), using wet environment and small systems works with the proper pipes, bearings and projects which is designed bearing housings manufactured by plastic material and assembled band pulley.

## AKPA PAN CONVEYOR WHEELS/PULLEYS

Pan conveyor transport systems are used as wheels of trays and buckets used in carrying clinkers in cement factories or material carriage in high temperatures. According to the project, they are manufactured at various diameters and measurements.

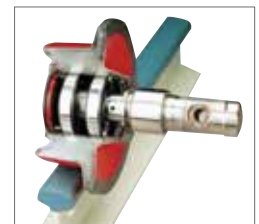

## AKRG 2 2-Group Garland Rollers

	AKRU1	AKRU3	AKRU4	AKRU5	AKRU6	AKRU7
Ø Shaft	20	25	26/25	30	32/30	40
Bearing	6204	6205	6305	6206	6306	6308

B	ØD	RL	EL	AL	TİP	p	V	O
500	60	315	343	363	AKRU1	25,40	64	751
	89	315	347	371	AKRU3	31,75	66	778
	108	315	347	371	AKRU4	31,75	66	778
	133	315	347	371	AKRU4	31,75	66	778
650	60	380	408	428	AKRU1	25,40	75	879
	89	380	412	436	AKRU3	31,75	77	906
	108	380	412	436	AKRU4	31,75	77	906
	133	380	420	452	AKRU5	38,10	80	940
800	60	465	493	513	AKRU1	25,40	90	1046
	89	465	497	521	AKRU3	31,75	92	1073
	108	465	497	521	AKRU4	31,75	92	1073
	133	465	505	637	AKRU5	38,10	94	1108
1000	63	600	628	648	AKRU1	25,40	113	1312
	89	600	632	656	AKRU3	31,75	115	1339
	108	600	632	656	AKRU4	31,75	115	1339
	133	600	640	672	AKRU5	38,10	118	1374
1200	159	700	728	748	AKRU1	25,40	131	1506
	89	700	732	756	AKRU3	31,75	133	1536
	108	700	732	756	AKRU4	31,75	133	1536
	133	700	740	772	AKRU5	38,10	135	1571
	159	700	744	776	AKRU7	44,45	137	1597
1400	89	800	828	848	AKRU1	25,40	148	1706
	108	800	832	856	AKRU3	31,75	150	1733
	133	800	832	856	AKRU4	31,75	150	1733
	159	800	840	872	AKRU5	38,10	152	1768
	194	800	844	876	AKRU7	44,45	154	1794
1600	89	900	932	956	AKRU3	31,75	167	1930
	108	900	932	956	AKRU4	31,75	167	1930
	133	900	940	972	AKRU5	38,10	170	1965
	159	900	944	976	AKRU7	44,45	172	1991
1800	108	1000	1032	1056	AKRU3	31,75	185	2127
	133	1000	1032	1056	AKRU4	31,75	185	2127
	159	1000	1040	1072	AKRU5	38,10	187	2162
	194	1000	1044	1076	AKRU7	44,45	189	2188
2000	133	1100	1132	1156	AKRU3	31,75	202	2324
	159	1100	1132	1156	AKRU4	31,75	202	2324
	194	1100	1140	1172	AKRU5	38,10	205	2359
	194	1100	1144	1176	AKRU7	44,45	206	2385
2200	133	1250	1282	1306	AKRU4	31,75	228	2619
	159	1250	1290	1322	AKRU6	38,10	231	2654
	194	1250	1294	1326	AKRU7	44,45	232	2681

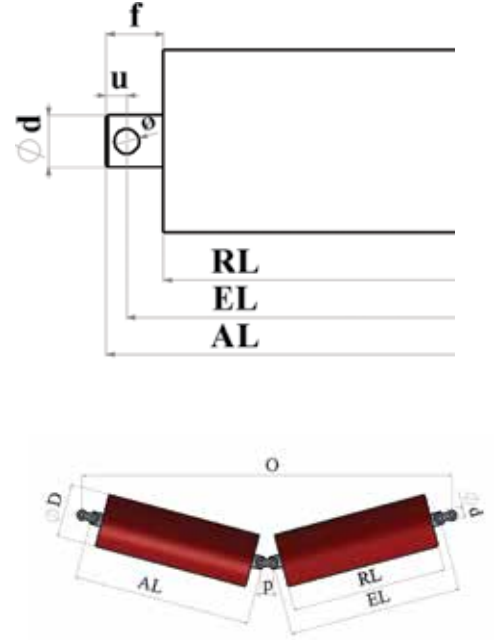



### AKRG 3 3-Group Garland Rollers

	AKRU1	AKRU3	AKRU4	AKRU5	AKRU6	AKRU7
Ø Shaft	20	25	26/25	30	32/30	40
Bearing	6204	6205	6305	6206	6306	6308

B	ØD	RL	EL	AL	TİP	p	V	O
500	60 89 108 133	200	228	248	AKRU1	25,40	153	692
		200	232	256	AKRU3	31,75	161	725
		200	232	256	AKRU4	31,75	161	725
		200	240	272	AKRU5	38,10	171	768
650	60 89 108 133	250	278	298	AKRU1	25,40	182	824
		250	282	306	AKRU3	31,75	190	857
		250	282	306	AKRU4	31,75	190	857
		250	290	322	AKRU5	38,10	200	900
800	60 89 108 133 159	315	343	363	AKRU1	25,40	219	995
		315	347	371	AKRU3	31,75	227	1028
		315	347	371	AKRU4	31,75	227	1028
		315	355	387	AKRU5	38,10	237	1072
1000	60 89 108 133 159	380	408	428	AKRU1	25,40	256	1166
		380	412	436	AKRU3	31,75	264	1200
		380	412	436	AKRU4	31,75	264	1200
		380	420	452	AKRU5	38,10	274	1243
1200	89 108 133 159	465	493	513	AKRU1	25,40	305	1391
		465	497	521	AKRU3	31,75	313	1424
		465	497	521	AKRU4	31,75	313	1424
		465	505	537	AKRU5	38,10	323	1467
		465	509	541	AKRU7	44,45	331	1501
1400	89 108 133 159 194	530	558	578	AKRU1	25,40	342	1562
		530	562	586	AKRU3	31,75	350	1595
		530	562	586	AKRU4	31,75	350	1595
		530	570	602	AKRU5	38,10	360	1639
		530	574	606	AKRU7	44,45	368	1672
1600	89 108 133 159 194	600	632	656	AKRU3	31,75	390	1780
		600	632	656	AKRU4	31,75	390	1780
		600	640	672	AKRU5	38,10	400	1824
		600	644	676	AKRU7	44,45	408	1857
1800	108 133 159 194	670	702	726	AKRU3	31,75	430	1965
		670	702	726	AKRU4	31,75	430	1965
		670	710	742	AKRU5	38,10	441	2008
		670	710	742	AKRU6	38,10	441	2008
		670	714	746	AKRU7	44,45	448	2041
2000	133 159 194	750	790	822	AKRU5	38,10	486	2219
		750	790	822	AKRU6	38,10	486	2219
		750	794	826	AKRU7	44,45	494	2252
2200	133 159 194	800	840	872	AKRU5	38,10	515	2351
		800	840	872	AKRU6	38,10	515	2351
		800	844	876	AKRU7	44,45	523	2384

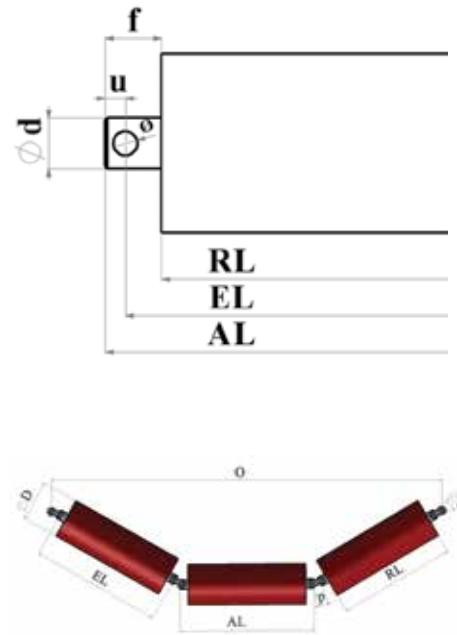

## AKRG 5 5-Group Garland Rollers

	AKRU1	AKRU3	AKRU4	AKRU5	AKRU6	AKRU7
Ø Shaft	20	25	26/25	30	32/30	40
Bearing	6204	6205	6305	6206	6306	6308

B	ØD	RL	EL	AL	TİP	p	V	O
800	89 108 133	165	193	213	AKRU1	25,40	326	810
		165	197	221	AKRU3	31,75	344	852
		165	197	221	AKRU4	31,75	344	853
		165	205	237	AKRU5	38,10	368	908
1000	89 108 133	205	233	253	AKRU1	25,40	384	956
		205	237	261	AKRU3	31,75	402	997
		205	237	261	AKRU4	31,75	402	997
		205	245	277	AKRU5	38,10	425	1054
1200	89 108 133 159	250	278	298	AKRU1	25,40	449	1120
		250	282	306	AKRU3	31,75	466	1161
		250	282	306	AKRU4	31,75	466	1161
		250	290	322	AKRU5	38,10	490	1217
		250	294	326	AKRU7	44,45	508	1259
1400	89 108 133 159 194	290	318	338	AKRU1	25,40	506	1265
		290	322	346	AKRU3	31,75	524	1307
		290	322	346	AKRU4	31,75	524	1307
		290	330	362	AKRU5	38,10	548	1363
		290	334	366	AKRU7	44,45	565	1404
1600	89 108 133 159 194	340	372	396	AKRU3	31,75	596	1489
		340	372	396	AKRU4	31,75	596	1489
		340	380	412	AKRU5	38,10	620	1545
		340	384	416	AKRU7	44,45	637	1568
1800	108 133 159 194	380	412	436	AKRU3	31,75	654	1634
		380	412	436	AKRU4	31,75	654	1634
		380	420	452	AKRU5	38,10	677	1690
		380	420	452	AKRU6	38,10	677	1690
		380	424	456	AKRU7	44,45	695	1732
2000	133 159 194	420	460	492	AKRU5	38,10	735	1836
		420	460	492	AKRU6	38,10	735	1836
		420	464	496	AKRU7	44,45	753	1877
2200	133 159 194	460	500	532	AKRU5	38,10	792	1981
		460	500	532	AKRU6	38,10	792	1981
		460	504	536	AKRU7	44,45	810	2023
2400	133 159 194	500	540	572	AKRU5	38,10	850	2127
		500	540	572	AKRU6	38,10	850	2127
		500	544	576	AKRU7	44,45	868	2169

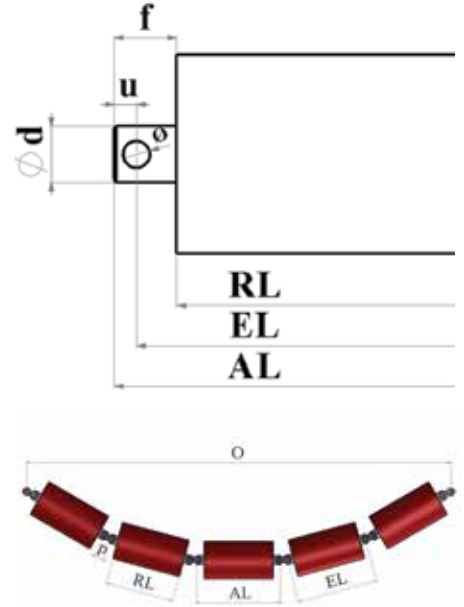

## CHASSIS

Carrying rollers are divided into two group: Upper Carrying Roller and Lower Carrying Rollers.

Rollers have two significant duties in belt conveyors:

- To support the belt carrying material or to main belt in return branch,
- To give chute shape to belt when necessary.

Upper carrying rollers (carries loaded band of belt) are comprised from a cylindrical roller which its length is longer than belt in simplest way. Such type straight roller groups are mostly used in transport of parts or with feeder belts. Conveyors with narrow belts located on transmission (transfer) machines (B= 300-400 mm) are used very rarely.

Another application is roller groups arranged in two, three and five units with V-angled. In this manner, carrying capacity of belt is increased. Three carrying roller groups containing a roller making angle with both sides and a horizontal roller are used between 20° - 45°. Even in the widest belts of today, standard three roller groups are used.





Rollers in general are being used on a chassis with steel construction. This chassis bearing rollers are connected to belt frame with bolts. In order to adjust rollers in vertical to belt movement, the holes on roller chassis are made oval. Design of roller chassis should be in a way to allow easily assembly and demounting of rollers easily. In wide rollers which carry heavy materials, attention should be paid that roller chassis has enough strength. Lower return rollers (carries empty return band of belt) are in generally single straight type but can have multi rollers in bigger systems (B >1200 mm)

**To ease roller carrying stations` recognition, these codes have been prepared. Please use these codes on your orders.**

### CHASSIS CODE: AKST3N, -, 800, T1.14, H160, ---, Bo

Code	Explanation
AKST3N	Order Code
-	Special Design
800	Belt Lentgh
T1.14	Switch Mouth Measurement
H160	H Height
---	Roller Length
Bo	Paint Type

Code	Explanation
Bo	Electro Static Powder Paint, Color Gray
Ga	Hot Dipping Galvanize, 10 micron
Sg	Cold Electro Galvanize, 10 micron

Code	Explanation	Figure
<b>AKST 2N</b>	Double Group on Carrying Chassis NPU	
<b>AKST 2L</b>	Double Group on Carrying Chassis Lama	
<b>AKST 3N</b>	Trio Group on Carrying Chassis NPU	
<b>AKST 3L</b>	Trio Group on Carrying Chassis Lama	
<b>AKSV 2N</b>	Double Group 10° on Bottom Return Chassis NPU	
<b>AKYU 3N</b>	Top Carrying Routing Chassis	
<b>AKYA 1N</b>	Single 0° on Bottom Carrying Routing Chassis NPU	
<b>AKYA 2N</b>	Double Group 10° on Bottom Carrying Routing Chassis NPU	
<b>AKDB</b>	Side Bracket for Return Rollers	

<b>NORM</b>	: NFE 53300
<b>ROLLERS</b>	: Ø60 – 89 – 108 - 133 mm, as 20 mm, SW14x10 mm
<b>PROTECTION</b>	: Epoxy coating
<b>ROUTE ANGLE</b>	: 2° according to working route

Belt Widht B (mm)	Ø D (mm)	AKST 3L		AKDB		K (mm)	G (mm)	h1 (mm)	Weight (Kg)				
		RL (mm)	EL (mm)	RL' (mm)	EL' (mm)				a [°]				
									20°	25°	30	35	45
400	60	150	158	475	508	570	466	100	5.8	6	6.1	6.4	
	89												
	108												
500	60	190	198	575	608	680	556	100	6.6	6.8	7	7.3	7.8
	89												
	108												
650	60	240	248	725	758	830	716	100	7.7	7.9	8.2	8.5	9.1
	89												
	108												
800	60	290 (285)	298	875	908	980	866	125	8.7	9	9.3	9.7	10.4
	89												
	108												
1000	89	360 (355)	368	1115	1148	1210	1106	125	11.6	12	12.4	12.8	11.9
	188												
	133												

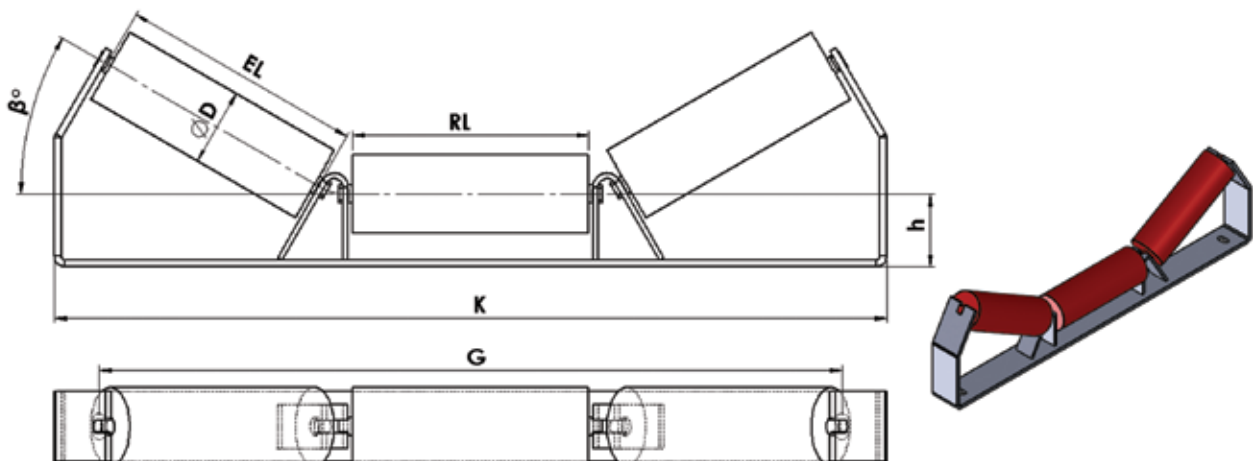

<b>NORM</b>	: DIN 22112-2
<b>ROLLERS</b>	: Ø60 — 89 — 108 — 133 — 159 mm, mil: 20 mm, SW 14x9 mm
<b>PROTECTION</b>	: Epoxy coating
<b>ROUTE ANGLE</b>	: 2° according to working route
<b>CODE</b>	: AKST 2N100

Belt Widht B [mm]	ØD [mm]	RL [mm]	EL [mm]	K [mm]	G [mm]	h1 [mm]	h [mm]	c [mm]	Weight (Kg)				
									a [°]				
									10°	15°	20°	25°	30°
400	60	250	258	700	640	75	125	160	6.7	6.8	8.0	7.2	7.4
	89					75	120						
	108					85	135						
500	60	315	323	800	740	75	125	160	7.4	7.6	7.7	7.9	8.1
	89					75	120						
	108					85	135						
650	60	380	388	950	890	75	125	160	8.5	8.7	8.9	9.1	9.3
	89					75	120						
	108					85	135						
	133					100	150						
800	60	465	473	1150	1090	75	125	160	10.0	10.2	10.5	10.7	11.0
	89					75	125						
	108					85	135						
	133					100	150						
1000	89	600	608	1350	1290	75	125	200	11.5	11.8	12,1	12,4	12,7
	108					85	135						
	133					100	150						
	159					130	180						
1200	89	600	608	1350	1290	75	125	200	13.0	13.3	13.7	14.0	14.3
	108					85	135						
	133					100	150						
	159					130	180						

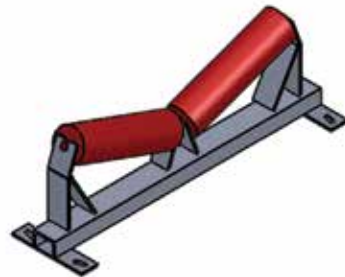
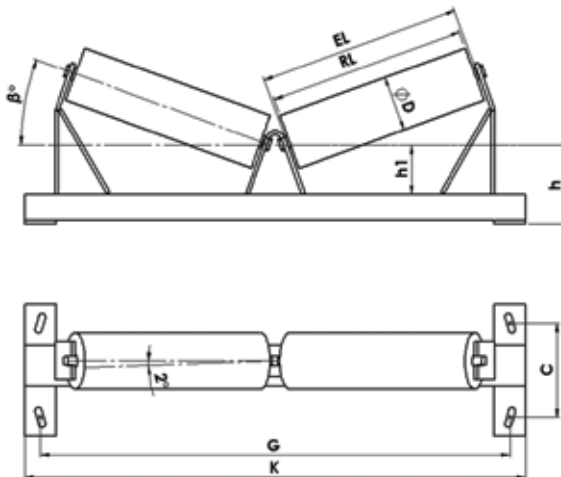

<b>NORM</b>	: DIN 22112-2
<b>ROLLERS</b>	: Ø60 — 89 — 108 — 133 — 159 mm, mil: 20mm, SW 15x9 mm
<b>PROTECTION</b>	: Epoxy coating
<b>ROUTE ANGLE</b>	: 2° according to working route
<b>CODE</b>	: AKST 3N100

Belt Width B [mm]	ØD [mm]	RL [mm]	EL [mm]	K [mm]	G [mm]	h1 [mm]	h [mm]	c [mm]	Weight (Kg)							
									a [°]							
									10°	15°	20°	25°	30°	35°	40°	45°
400	60	165	173	700	640	75	125	160	6.7	6.8	7.0	7.2	7.4	7.6	7.8	8.1
	89					75	125									
	108					85	135									
500	60	200	208	800	740	75	125	160	7.4	7.6	7.7	7.9	8.1	8.3	8.5	8.8
	89					75	125									
	108					85	135									
650	60	250	258	950	890	75	125	160	8.6	8.7	8.9	9.1	9.4	9.6	9.9	10.2
	89					75	125									
	108					85	135									
	133					100	150									
800	60	315	323	1150	1090	75	125	160	10.0	10.2	10.5	10.7	11.0	11.3	11.7	12.1
	89					75	125									
	108					85	135									
	133					100	150									
1000	89	380	388	1350	1290	75	125	200	12.1	12.2	12.3	12.5	12.7	13.1	13.5	14.0
	108					85	135									
	133					100	150									
	159					130	180									
1200	89	465	473	1600	1540	75	125	200	13.4	13.9	14.3	14.5	14.8	15.3	15.8	16.4
	108					85	135									
	133					100	150									
	159					130	180									

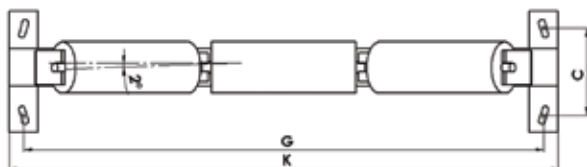
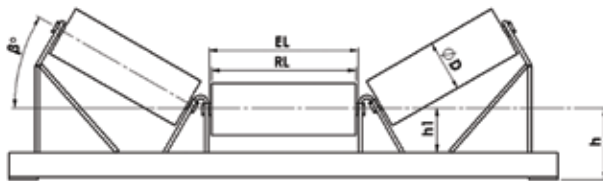

<b>NORM</b>	: DIN 22112-2
<b>ROLLERS</b>	: Ø 89 – 108 – 133 – 159mm, SW 14-18-22 mm
<b>PROTECTION</b>	: Epoxy Coating
<b>ROUTE ANGLE</b>	: 2° according to working route
<b>CODE</b>	: AKSV 2K

Belt Width B [mm]	ØD [mm]	RL [mm]	EL [mm]	G [mm]	K [mm]	h1 [mm]	h [mm]	c [mm]
650	89	380	388	890	950	75	120	165
	108					100	145	212
800	89	465	473	1090	1150	75	120	165
	108					100	145	212
1000	89	600	608	1290	1350	75	120	165
	108					100	145	212
	133					100	150	217
1200	89	700	708	1540	1600	75	125	170
	108					85	135	189
	133					100	150	217
	159					130	180	218
1400	108	800	808	1740	1800	85	135	217
	133					100	150	218
	159					130	180	200
1600	133	900	908	1940	2000	100	150	217
	159					130	180	218
1800	133	1000	1008	2140	2200	100	150	217
	159					130	180	218
2000	133	1100	1108	2340	2400	100	150	217

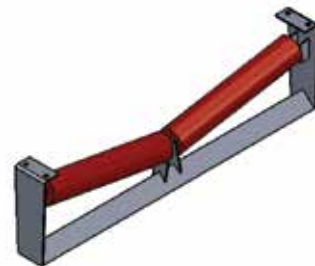
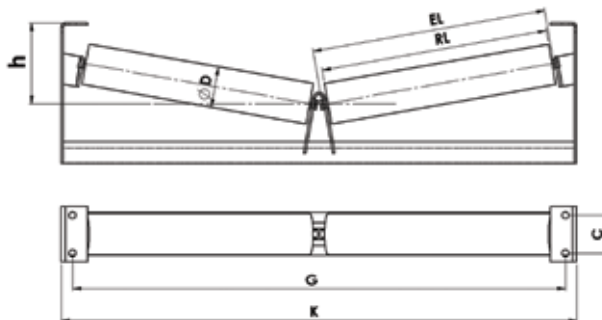



## SIDE BRACKET FOR RETURN ROLLERS

AKDB SIDE BRACKET Y-TYPE

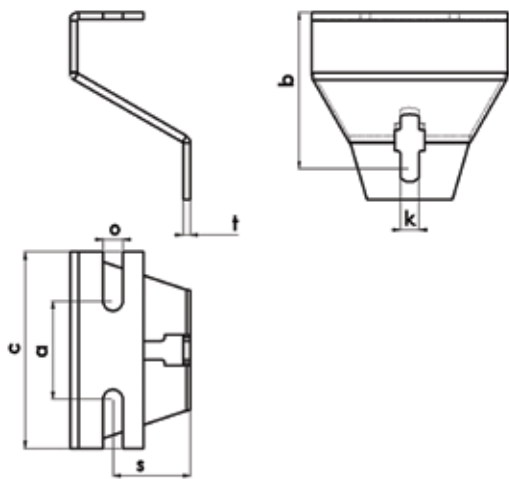

AKDB SIDE BRACKET Z-TYPE

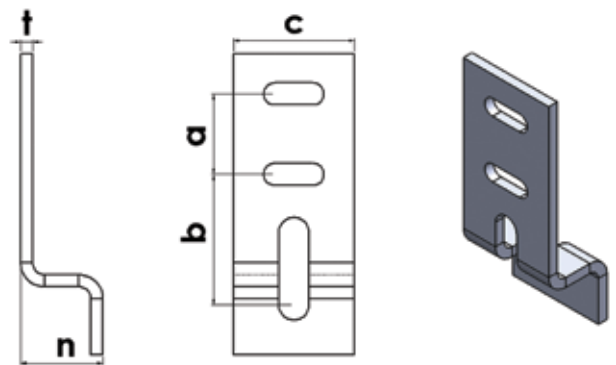

AKDB SIDE BRACKET STRAIGHT TYPE

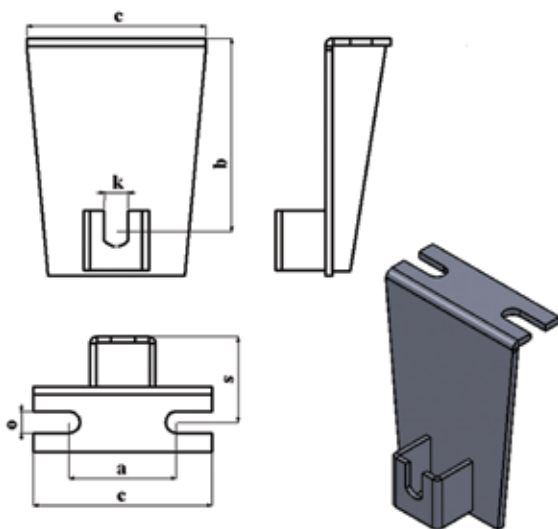

AKDB SIDE BRACKET C-TYPE

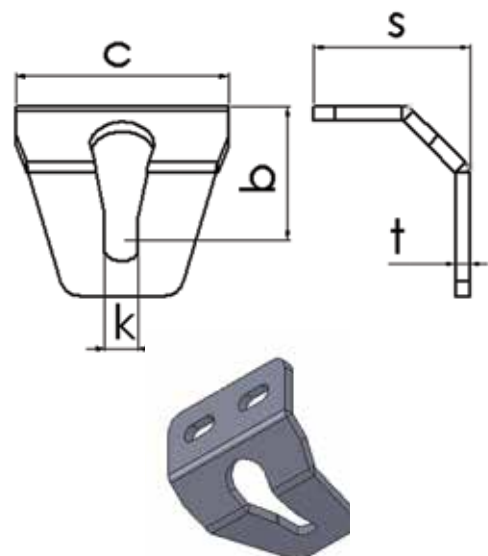

## Centring Apparatus/ Routing Station:

It is necessary to keep the belt axis of belt conveyors remain on conveyor axis. Belt slope off will cause material pouring and belt damage. Centring of belt is easy for straight pulleys.

### The following matters increase the probability of sloping off of belt:

- Increase of angle of inclination
- Big distance between rollers
- Loading far from centre
- Accumulation of material,
- High speed of belt
- Insufficient fitting on roller of belt
- Congestion and difficulty in turning of rollers and drums
- Adhering material on drums and rollers
- Wind effect at conveyors operated outdoor
- Irregular structure of joint of belt strap
- Fitting on medium rollers of belt due to its rigidity,
- Failing to fit rollers and drums in full vertical to axis of conveyor
- Inadequacy of the routing and levelling of belt chassis

### The constructive measures to be taken for belt movement at center are:

- a) Positioning in  $1.5^{\circ}$  -  $3^{\circ}$  inclined of side rollers in the movement routing of belt,
- b) Making convex of head and tail drums,
- c) Using fixed guide rollers. Side guide rollers are fixed on each side of belt chassis restricts movement of belt laterally, contacting with belt side. As it will lead to abrasion in belt sides, it is recommended not to use for the conveyors with long belt.
- d) Using guide rollers groups. In order to escape of belt on pulleys, special "belt guide stations" in various types are being used. These pulleys make belt centring automatically. A belt guidance station (or self-centralizer as mentioned) escapes from belt axis, belt side touches guide roller with a light pressure. This effect rotates chassis of pulley set up to a certain angle according to axis, length of conveyor. When belt is centred, it brings guide roller set to first situation automatically.



## AKYU UPPER ROUTING STATIONS

Upper routing stations are inserted between the top carrying stations in the system. They are being manufactured with same measurements and have the same design. Roller center and station connection centers should be the same.

<b>NORM</b>	: DIN 22112-2
<b>ROLLERS</b>	: Ø 89 — 108 — 133 — 159 mm, mil: 20 mm, SW 14x9 mm
<b>PROTECTION</b>	: Epoxy Coating
<b>ROUTING ANGLE</b>	: 2° according to working route
<b>CODE</b>	: AKYU 3N120

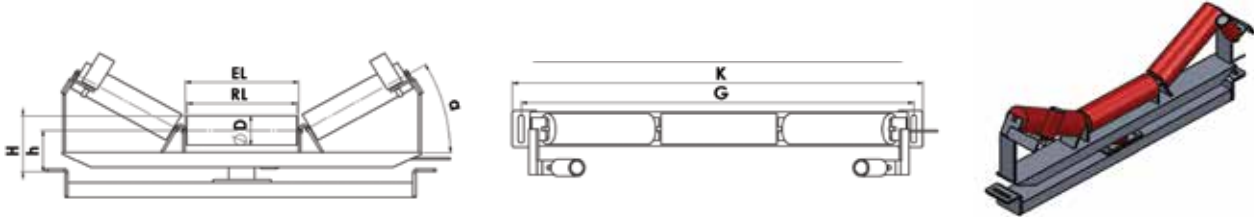

Belt Width B [mm]	ØD [mm]	RL [mm]	EL [mm]	G [mm]	K [mm]	h1 [mm]	h [mm]	H [mm]	Weight (Kg)			
									a [°]			
									30°	35°	40°	45°
400	60	165	173	640	700	75	120	152				
	89					75	120	165				
	108					85	130	184				
500	60	315	323	740	800	75	120	152				
	89					75	120	165				
	108					85	130	184				
650	60	380	388	890	950	75	120	152				
	89					75	120	165				
	108					100	145	212				
800	60	465	473	1090	1150	75	120	152				
	89					75	120	165				
	108					100	145	212				
1000	89	600	608	1290	1350	75	120	165				
	108					100	145	212				
	133					100	150	217				
1200	89	465	473	1540	1600	75	125	170				
	108					85	135	189				
	133					100	150	217				
	159					130	180	218				
1400	1058	530	538	1740	1800	85	135	189				
	133					100	150	217				
	159					130	180	218				
1600	133	600	608	1940	2000	100	150	217				
	159					130	180	218				

## AKYA SINGLE GROUP LOWER ROUTING

Double and single straight guide rollers, for loaded and empty straps, are working as explained above.

Lower routing stations are inserted between the bottom return stations in the system. They are being manufactured with same measurements and have the same design. Roller center and station connection centers should be the same.

<b>NORM</b>	: DIN 22112-2
<b>ROLLERS</b>	: Ø 89 — 108 — 133 — 159 mm, SW 14-18-22 mm
<b>PROTECTION</b>	: Epoxy Coating
<b>CODE</b>	: AKYA 1N

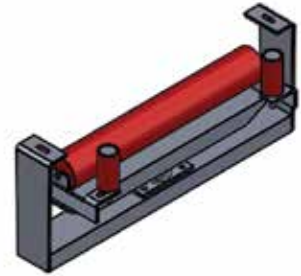
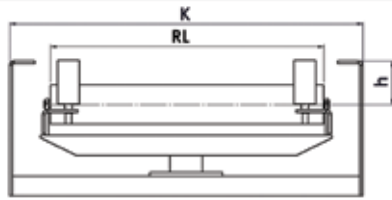

Belt Width B [mm]	ØD [mm]	RL [mm]	EL [mm]	G [mm]	K [mm]	h1 [mm]	h [mm]	H [mm]	Wight (Kg)
									a [°] 0°
400	89	500	508	640	700	75	120	165	
	108					85	130	184	
500	89	600	608	740	800	75	120	165	
	108					85	130	184	
650	89	750	758	890	950	75	120	165	
	108					100	145	212	
800	89	950	958	1090	1150	75	120	165	
	108					100	145	212	
1000	89	1150	1158	1290	1350	75	120	165	
	108					100	145	212	
	133					100	150	217	
1200	89	1400	1408	1540	1600	75	125	170	
	108					85	135	189	
	133					100	150	217	
	159					130	180	218	
1400	108	1600	1608	1740	1800	85	135	189	
	133					100	150	217	
	159					130	180	218	
1600	133	1800	1808	1940	2000	100	150	217	
	159					130	180	218	

## DRUMS

AKKAYALAR CONVEYOR manufactures belt drums in the types stated below according to projects and needs of customers so as to be used in conveyor system.

### DRUM DEFINITIONS ABBREVIATIONS. AKTT -630, -750, -40, BO, DK, 12

Code	Definition
<b>AKTT</b>	Drum Type
<b>-630</b>	Drum Pipe Diameter
<b>-750</b>	Drum Pipe Length
<b>-40</b>	Drum Shaft Diameter – Bearing Housing Diameter
<b>BO</b>	Pipe Paint System
<b>DK</b>	Rubber Coating Type
<b>-12</b>	Rubber Thickness

<b>AKTT</b>	Driving Drum
<b>AKTK</b>	Tail Drum
<b>AKTS</b>	Diversion Drum
<b>AKTC</b>	Cleaning Rods Drum
<b>AKTE</b>	Elevator Drum

<b>PO</b>	Painted with Rust Preventer
<b>KG</b>	Sanded + Galvanized Coating 70 micron
<b>OB</b>	Special paint on request

<b>DK</b>	Lagged in Smooth Rubber
<b>BK</b>	Lagged in Diamond Pattern
<b>VT</b>	Lagged in Herringbone Pattern,sense anti-clockwise
<b>VD</b>	Lagged in Herringbone Pattern,sense clockwise
<b>SE</b>	Industrial Type Ceramic Coating

### Drum Pipe Length:

The length of drum pipe is being taken 50mm wider than belt width for up to 1000mm belt width, and 75-100mm longer than belt width for belt width wider than 1000mm.

### Drum Pipe Diameter:

Taking drum diameters smaller due to belt camber in drums is harmful in terms of belt life. But however, taking diameters bigger is not appropriate in terms of economy. In the driving drums where belt powers are bigger, diameter should be bigger than other drums. Also, selecting driving drum bigger than necessary, since it will cause upsizing in reducer, it will increase the cost.

### Drum Shaft Diameter:

Although shafts of driving drums they are exposed both to bending and twisting, auxiliary drums` shafts are only exposed to bending. Driving drums` shafts returns with the drum, and shafts of auxiliary drums can be fixed or turning. After the calculation of momentum and bed powers of bending and twisting in shafts, shaft diameters can be chosen with the help of various figure and tables.



**AKKAYALAR CONVEYOR belt drums primarily covers:**

### ***Drum Body:***

For sizes smaller than  $\varnothing 600$  mm, steel drawing type pipes are being used with the thickness such as 0-15 mm according to DIN 2448. For sizes same or bigger than  $\varnothing 600$  mm, the pipes produced by Ereğli with iron sheet folding method by using St 37,2 - St 52 material with suitable thickness according to the project. By giving taper of  $1^\circ$  per 3/2 on outer surfaces of drum pipes, trip, slide of belt will be prevented. Diameters of drum pipes changes between 220 mm and 1400 mm according to length and width of belt calculated as per load to be carried and surface width are between 400 mm and 3000 mm.



### ***Rubber Coating:***

Mostly used in driving drums. For better grabbing, it is grounded at thickness 10-25 mm with the hardness of  $65 \pm 5$  Shore, in herringbone or diamond pattern. It is being manufactured in hot vulcanized type according to hardness value suitable for project. In addition, ceramic coating is also available at the request.



### ***Ceramic Lagging:***

Against to abrasion, ceramic is most commonly used at drums of conveyor belts. Industrial ceramic which has the diamond hardness is not exposed to abrasion and its operating span is between 8-10 years. It removes the problems of skid and belt abrasion with its perfect grasps (two times of rubber lagging), it minimizes diameter of drums and transfers double drive drum systems to single drums. Drive profiles center the band and the band does not move to the side, so there is no need to take additional measurement.



### ***Shafts:***

Driving shafts are single or double powered shafts. They are being manufactured after machining in sensitivity convenient for standards according to connection housings in tail, tension and diversion drums as well. Shafts are amounted in a way all surfaces are machined, without balance from  $\text{Ç}1050$  -  $\text{Ç}4140$  quality. Depending on working conditions of conveyor, qualities, lengths and diameters of shaft also changing.



### ***Tightening Clamps:***

It ensures connection of drum pipe of shaft via flange. It is manufactured in two parts and conic tightened each other, its inner part grabs shaft, outer part is welded flange. Capped and straight types, product of our firm are also available. Thickness of shafts changes between  $\varnothing 40$  mm -  $\varnothing 230$ mm.



### ***Flanges:***

It provides connection of drum pipet conic tightened clamps. It is machined from casted GS52 - GS45 quality or St37,2 - St 52 quality iron sheet and in thickness eligible for project and merged to pipe with welding.



### ***Corrosion protection:***

Painting procedure is applied on the surfaces that rubber coating is not made and the side flanges. Exposed edges of shaft are lubricated and protected with protective oil against corrosion.

**General:** Static "oscillation" balances of all drums are taken by our firm, dynamic balances are carried out upon request.

## AKTT DRIVING DRUM

It is the drum that gives movement to belt strap on conveyor system. In case of belt length being long, number of driving drums can be more than one. In the single driving drums, there are Euler connection between the forces in driving drum and convolution angle. In such belt, to increase pulling force, it is required to increase winding angle and friction factors. Thus, winding angle can be increased up to 500 degrees. Friction factor between rubber coated steel pipe drums belt and drum is around 0,05 and 0,45. To deliver the power on the conveyor with less pulling force, it is necessary to increase the friction factor. For this reason driving drums are coated with rubber with 10-20mm thickness. In this case, friction factor differs between 0,20 – 0,60. To remain in the safe side on calculations, friction factor is considered as 0,25 on bare drums and 0,35 on rubber coated ones.

In our products, our drums have detachable shafts, and connected to drum pipe with forceps system.

Also, during the drum manufacturing of our firm, shaft connection features are conducted in line with the following given information.

**AKTT FP. As sheet metal, coupling half and capped or straight type clamps of our manufacturing.**

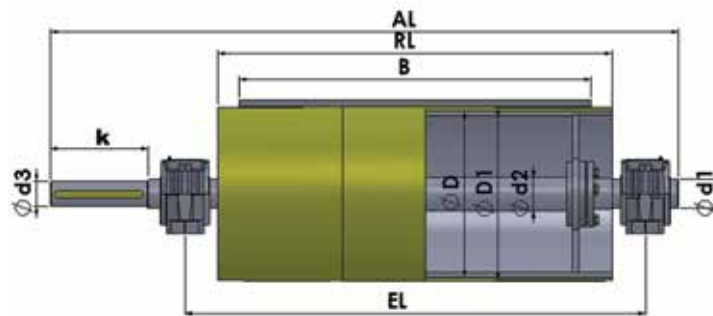

**AKTT FF As sheet metal, coupling half and conical pressed clamps (taper lock).**

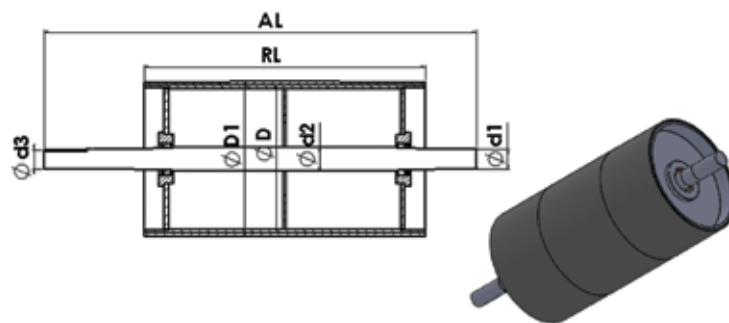

**AKTT DF As pouring coupling half and conical pressed clamps (taper lock)**

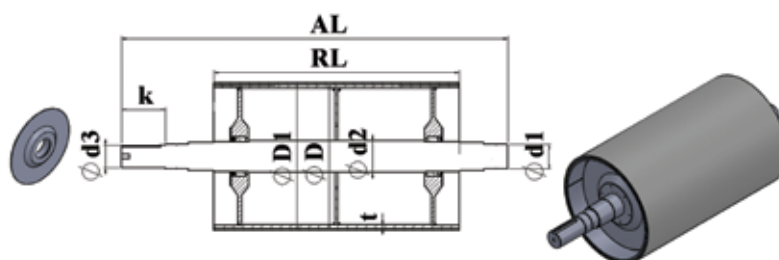

## AKTT DRIVING DRUM

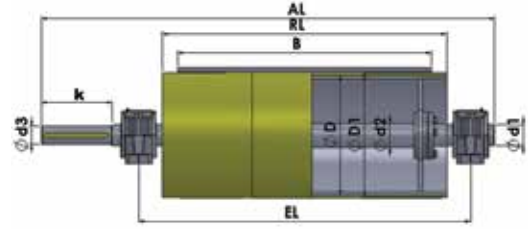

B	RL	EL	D	AL	d1	d2	d3	k	Gn (kg)	Housing
300	400	535	215	790	50	60	45	110	46.4	SN 511
		535	240	790	50	60	45	110	49.8	SN 511
		535	270	790	50	60	45	110	56.4	SN 511
		550	320	830	60	70	55	120	73.6	SN 513
400	500	625	215	840	40	50	35	80	45.5	SN 509
		635	240	890	50	60	45	110	57.2	SN 511
		650	320	930	60	70	55	120	84.2	SN 513
		650	400	930	60	70	55	120	109.4	SN 513
500	600	735	240	990	50	60	45	110	65	SN 511
		750	270	1030	60	70	55	120	86.1	SN 513
		760	320	1070	70	80	65	140	110.4	SN 516
		785	400	1120	80	90	75	140	154.4	SN 518
		800	500	1170	90	100	80	160	214.3	SN 520
650	750	885	320	1140	50	60	45	110	96.9	SN 511
		900	400	1180	60	70	55	120	145	SN 513
		910	500	1220	70	80	65	140	197.1	SN 516
		935	500	1270	80	90	75	140	212.9	SN 518
		950	630	1320	90	100	85	160	307.5	SN 520
		965	800	1350	100	110	95	160	441.9	SN 522
800	950	1085	400	1340	50	60	45	110	155.4	SN 511
		1100	400	1380	60	70	55	120	171.8	SN 513
		1110	500	1420	70	80	65	140	213.1	SN 516
		1135	500	1470	80	90	75	140	249.1	SN 518
		1150	630	1520	90	100	85	160	360.2	SN 520
		1165	630	1550	100	110	95	160	395.5	SN 522
		1175	800	1590	110	120	105	180	538.5	SN 524
		1195	1000	1650	125	140	110	200	767.6	SN 528
1000	1150	1310	400	1620	70	80	65	140	219.3	SN 516
		1335	400	1670	80	90	75	140	239.4	SN 518
		1350	500	1720	90	100	85	160	307.3	SN 520
		1365	500	1750	100	110	95	160	340.4	SN 522
		1375	630	1790	110	120	100	180	479	SN 524
		1395	800	1850	125	140	110	200	667.1	SN 528
		1410	1000	1900	135	150	120	220	910.3	SN 530
		1425	1250	1930	140	160	130	220	1326.7	SN 532



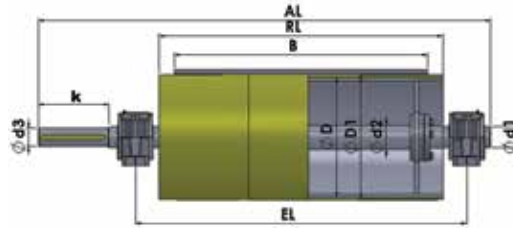

B	RL	EL	D	AL	d1	d2	d3	k	Gn (kg)	Housing
1200	1400	1585	500	1920	80	90	75	140	326.7	SN 518
		1600	500	1970	90	100	85	160	353.1	SN 520
		1615	630	2000	100	110	95	160	515.8	SN 522
		1625	630	2040	110	120	105	180	549	SN 524
		1645	800	2100	125	140	110	200	763	SN 528
		1660	1000	2150	135	150	125	220	1039	SN 530
		1675	1000	2180	140	160	130	220	1132	SN 532
		1710	1250	2270	160	180	140	240	1,541.0	SN 534
1400	1600	1785	500	2120	80	90	75	140	557.8	SN 518
		1800	500	2170	90	100	85	160	585.4	SN 520
		1815	630	2200	100	110	95	160	746.7	SN 522
		1825	630	2240	110	120	105	180	780.8	SN 524
		1845	800	2300	125	140	110	200	1,155.5	SN 528
		1860	800	2350	135	150	125	220	1,201.8	SN 530
		1875	1000	2380	140	160	130	220	1,513.5	SN 532
		1910	1250	2470	160	180	140	240	2,039.9	SN 534
1600	1800	1985	500	2320	80	90	75	140	657.4	SN 518
		2000	500	2370	90	100	85	160	687.3	SN 520
		2015	630	2400	100	110	95	160	873.8	SN 522
		2025	630	2440	110	120	105	180	910.7	SN 524
		2045	800	2500	125	140	110	200	1,232.7	SN 528
		2060	1000	2550	135	150	125	220	1,561.0	SN 530
		2075	1250	2580	140	160	130	220	2,112.0	SN 532
		2110	1250	2670	160	180	140	240	2,261.9	SN 534
1800	2000	2185	500	2520	80	90	75	140	719.3	SN 518
		2200	500	2570	90	100	85	160	751.6	SN 520
		2215	630	2600	100	110	95	160	953.5	SN 522
		2225	630	2640	110	120	105	180	993.3	SN 524
		2245	800	2700	125	140	110	200	1,340.4	SN 528
		2260	800	2750	135	150	125	220	1,393.9	SN 530
		2260	1000	2750	135	150	125	220	1,692.5	SN 530
		2275	1000	2780	140	160	130	220	1,746.1	SN 532
		2275	1250	2780	140	160	130	220	2,285.7	SN 532
		2310	1250	2870	160	180	140	240	2,404.1	SN 534
2000	2200	2400	500	2770	90	100	85	160	815.9	SN 520
		2415	630	2800	100	110	95	160	1,033.2	SN 522
		2425	630	2840	110	120	105	180	1,075.9	SN 524
		2445	800	2900	125	140	110	200	1,435.4	SN 528
		2460	1000	2950	135	150	125	220	1,928.9	SN 530
		2475	1250	2980	140	160	130	220	2,459.4	SN 532
		2510	1250	3070	160	180	140	240	2,586.2	SN 534

## AKTK Tail/Snup Drum

In case of belt length being short, it is inserted to end of the belt as tail drum and connected to turnbuckle system drum shaft. In case of belt length being long, as well as it can be connected to the end as tail drum, it can also be used with the weight mechanism in the belt turnbuckle system. In general, rubber coating is not applied on drum body pipe. It is a detachable shaft and connected to drum pipe with clamp system.

## AKTS Diversion Drum

They have smaller diameters compared to driving and tail drums. Their duties are being clung to snub and driving drums, and provide their routing. They are detachable and connected to drum pipe with clamp system. Also, during the manufacturing, our firm conducts the shaft connection features in line with the following given information.

**AKTT FP. As sheet metal, coupling half and capped or straight type clamps of our manufacturing.**

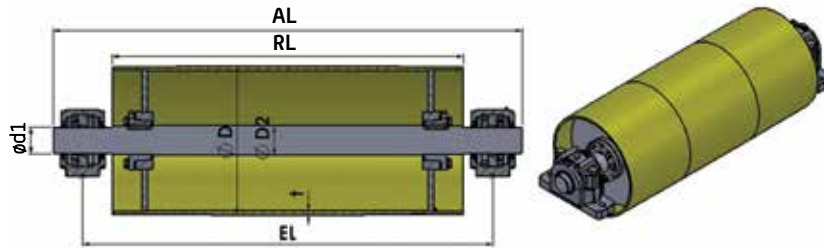

**AKTT FF As sheet metal, coupling half and conical pressed clamps (taper lock).**

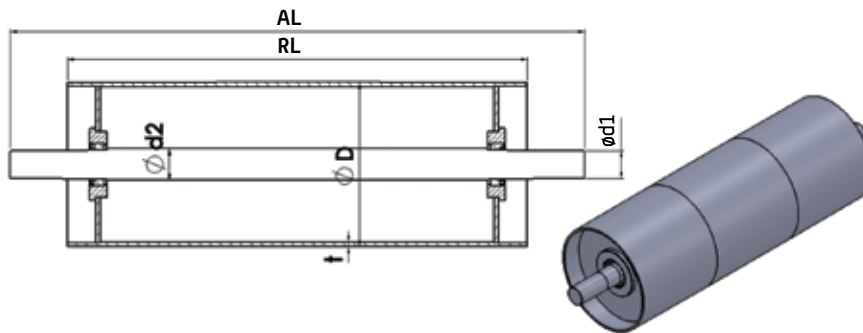

**AKTT DF As pouring coupling half and conical pressed clamps (taper lock)**

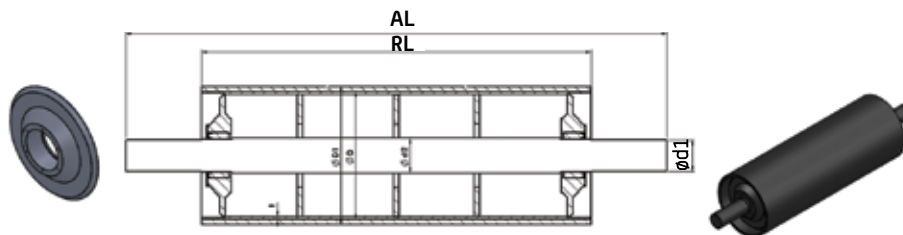

## TAIL / TENSION DRUM

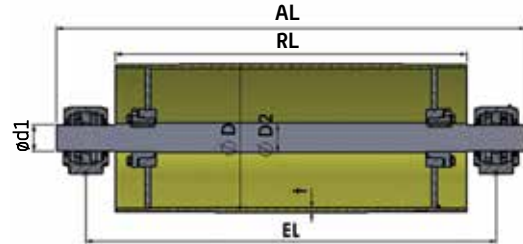

B	RL	EL	D	AL	d1	d2	Gn (kg)	Housing
300	400	490	190	690	40	50	35	UCT 208
		490	215	690	40	50	39	UCT 208
		490	240	690	40	50	42	UCT 208
		495	270	695	50	60	55	UCT 210
400	500	590	190	790	40	50	41	UCT 208
		590	215	790	40	50	45	UCT 208
		590	240	790	40	50	49	UCT 208
		595	270	795	50	60	64	UCT 210
		595	320	795	50	60	72	UCT 210
500	600	690	240	920	40	50	56	UCT 208
		695	270	925	50	60	72	UCT 210
		750	320	980	60	70	93	SNH 513
		750	400	980	60	70	122	SNH 513
		760	500	990	70	80	166	SNH 516
650	750	845	270	1085	50	60	85	UCT 210
		900	320	1140	60	70	109	SNH 513
		910	400	1150	70	80	158	SNH 516
		930	500	1170	80	90	207	SNH 518
		950	630	1190	90	100	298	SNH 520
800	950	1045	270	1285	50	60	101	UCT 210
		1100	320	1340	60	70	128	SNH 513
		1110	400	1350	70	80	187	SNH 516
		1130	500	1370	80	90	243	SNH 518
		1150	630	1390	90	100	351	SNH 520
1000	1150	1245	270	1485	50	60	116	UCT 210
		1300	320	1540	60	70	147	SNH 513
		1310	400	1550	70	80	215	SNH 516
		1330	500	1570	80	90	278	SNH 518
		1350	630	1590	90	100	402	SNH 520
		1365	800	1605	100	110	568	SNH 522
		1375	1000	1615	110	120	795	SNH 524

## TAIL / TENSION DRUM

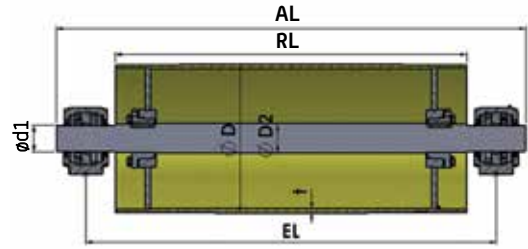

B	RL	EL	D	AL	d1	d2	Gn (kg)	Housing
1200	1400	1550	400	1800	60	70	227	SNH 513
		1560	400	1810	70	80	249	SNH 516
		1580	500	1830	80	90	320	SNH 518
		1600	630	1850	90	100	465	SNH 520
		1615	800	1865	100	110	652	SNH 522
		1645	1000	1895	125	130	943	SNH 528
1400	1600	1780	500	2010	80	90	432	SNH 518
		1800	500	2030	90	100	456	SNH 520
		1815	630	2045	100	110	578	SNH 522
		1825	630	2055	110	120	616	SNH 524
		1825	800	2055	110	120	859	SNH 524
		1845	800	2075	125	130	892	SNH 528
		1845	1000	2075	125	130	1,109	SNH 528
		1860	1000	2090	135	150	1,182	SNH 530
1600	1800	2000	500	2300	90	100	539	SNH 520
		2015	630	2315	100	110	715	SNH 522
		2025	630	2325	110	120	748	SNH 524
		2025	800	2325	110	120	945	SNH 524
		2045	800	2345	125	130	983	SNH 528
		2045	1000	2345	125	130	1,215	SNH 528
		2060	1000	2360	135	150	1,297	SNH 530
1800	2000	2200	500	2500	90	100	587	SNH 520
		2215	630	2515	100	110	778	SNH 522
		2225	800	2525	110	120	1,016	SNH 524
		2245	800	2545	125	130	1,056	SNH 528
		2225	1000	2525	110	120	1,273	SNH 524
		2260	1000	2560	135	150	1,313	SNH 530
2000	2200	2415	500	2715	100	110	697	SNH 522
		2425	630	2725	110	120	880	SNH 524
		2445	630	2745	125	130	924	SNH 528
		2425	800	2725	110	120	1,095	SNH 524
		2445	800	2745	125	130	1,138	SNH 528
		2445	1000	2745	125	130	1,569	SNH 528
		2460	1000	2760	135	150	1,665	SNH 530

## AKTE Elavator's Driving and Tail Drums

They can be manufactured in desired diameters and sizes to be used in elevator systems according to project. It is with detachable shaft, connected to drum pipe via clamp system.

**AKTE TH Elevator Driving Drums**

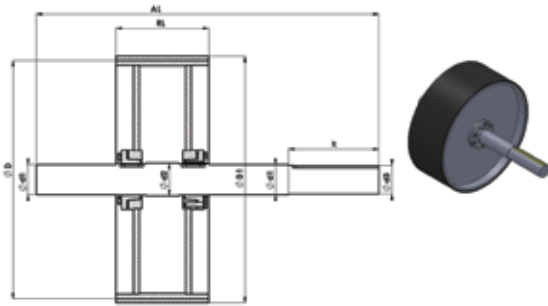

**AKTE KY Elevator Tail Drums**

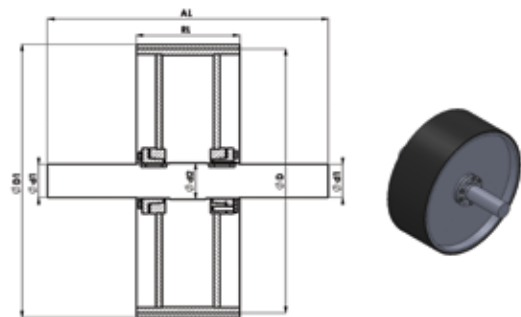

## AKTC Barred Cleaning Drum

As barred drums are usually inserted to tails in the system, they can also be used as driving drums. The bars placed over the side flanges are cleaning foreign substances stuck on the belt surface in order not to damage the belt.

They are detachable and connected to drum pipe with clamp system.

**AKTC TH Barred Cleaning Driving Drum**

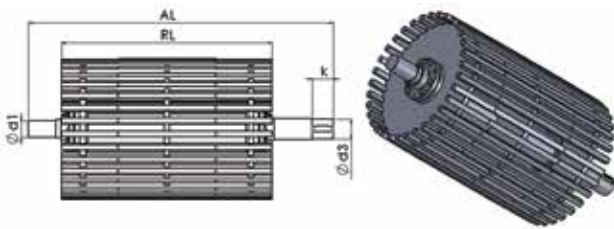

**AKTC KY Barred Cleaning Tail Drum**

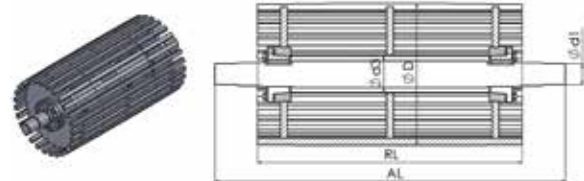

B	RL	EL	D	D1	AL	d1	d2	d3	k

To ask for prices of these drums and order, please fill the gaps in the related table and send it to us by filling suitable measurements.

## DRUM SPARES

Two part-conic system tightening clamps are being used for connection of drum shaft to drum pipe, manufactured by Ç1050 material shafts in our firm. We use these in drums we manufacture in our firm, and also sale itself. Thickness of shafts changes between Ø40 mm - Ø230mm. Two types in capped and straight are available. Our recommendation for drums with big diameter and to be operated under hard conditions is use of capped type.

For your conical pressed clamps requests, you can use the following codes.

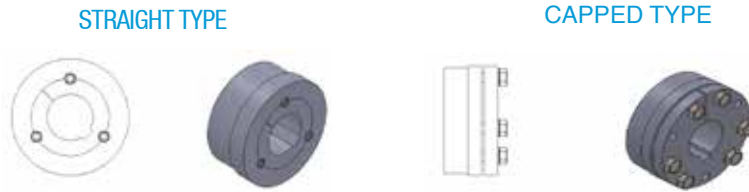

Code of Straight type Clamp	Diameter Of Shaft Ø d	Code of Capped type Clamp	Diameter Of Shaft Ø d	Code of Capped type Clamp
2517/040 PD	Ø 40 mm	2517/040 PS	Ø 140 mm	4545/140 PS
2517/045 PD	Ø 45 mm	2517/045 PS	Ø 145 mm	4545/145 PS
2517/050 PD	Ø 50 mm	2517/050 PS	Ø 150 mm	5050/150 PS
2517/055 PD	Ø 55 mm	2517/055 PS	Ø 155 mm	5050/155 PS
3020/060 PD	Ø 60 mm	3020/060 PS	Ø 160 mm	5050/160 PS
3020/065 PD	Ø 65 mm	3020/065 PS	Ø 165 mm	5050/165 PS
3020/070 PD	Ø 70 mm	3020/070 PS	Ø 170 mm	5050/170 PS
3020/075 PD	Ø 75 mm	3020/075 PS	Ø 175 mm	5555/175 PS
3535/080 PD	Ø 80 mm	3535/080 PS	Ø 180 mm	5555/180 PS
3535/085 PD	Ø 85 mm	3535/085 PS	Ø 185 mm	5555/185 PS
3535/090 PD	Ø 90 mm	3535/090 PS	Ø 190 mm	5555/190 PS
3535/095 PD	Ø 95 mm	3535/095 PS	Ø 195 mm	5555/195 PS
4040/100 PD	Ø 100 mm	4040/100 PS	Ø 200 mm	5555/200 PS
4040/105 PD	Ø 105 mm	4040/105 PS	Ø 215 mm	5555/215 PS
4545/110 PD	Ø 110 mm	4040/110 PS	Ø 220 mm	5555/220 PS
4545/115 PD	Ø 115 mm	4040/115 PS	Ø 225 mm	5555/225 PS
5050/120 PD	Ø 120 mm	4545/120 PS	Ø 230 mm	5555/230 PS
5050/125 PD	Ø 125 mm	4545/125 PS		
5050/130 PD	Ø 130 mm	4545/130 PS		
5050/135 PD	Ø 135 mm	4545/135 PS		

## TAPER LOCK SYSTEMS:

We market taper lock systems in various diameters which are used various transferring items 'pulleys, drums, wheels, gears, cylinders etc...' connecting to shafts, for fixing without any need of wedge.



## BEARING HOUSING,

Bearing housing are being manufactured by iron sheets in thickness of 2, 3, 4, 5 mm suitable for drawing, at HRP A quality, product of Ereğli by pressing i with moulds in press machines in our factory. These are produced in compatible with the pipes with diameters of Ø60, 76, 89, 102, 108, 114, 127, 133, 139, 159 mm and bearing sizes of 6204, 6205, 6206, 6305, 6306, 6308. Two housing type in straight type and skirted type are available. Skirted type has only 2 mm thickness and is produced for sale purpose.

STRAIGHT TYPE



SKIRTED TYPE



POLIAMID HOUSING TYPE



**Bearing houses are being composed of 4 parts in our sales. These are**

- Iron sheet convenient for pipe diameter and bearing to be used,
- Inner and outer labyrinth set resistant against 180- 200°C temperature, made from polyamide 6 material in accordance with the bearing to be used,
- Metal dust cover which prevents entrance of dust and water,
- Plastic dust cover conforming to shaft diameter,

STRAIGHT TYPE



SKIRTED TYPE

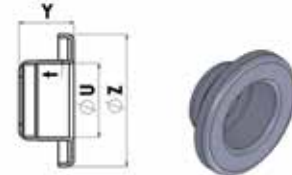

## SIZE TABLE OF BEARING HOUSING

Pipe ØD	Bearing Size	Type	Code	Housing Size mm				Wight Gr
				Ø Z	Ø U	t	Y	
76 mm	6204 (20*47) mm	SKIRTED	AKYE 076/24	72	47	2	38	165
89 mm	6204 (20*47) mm	SKIRTED	AKYE 089/24	85	47	2	38	180
102 mm	6204 (20*47) mm	SKIRTED	AKYE 102/24	98	47	2	38	202
60 mm	6204 (20*47) mm	STRAIGHT	AKYD 060/24	57	47	2	50	130
76 mm	6204 (20*47) mm	STRAIGHT	AKYD 076/24	72	47	2	50	150
89 mm	6204 (20*47) mm	STRAIGHT	AKYD 089/24	85	47	2	50	171
108 mm	6204 (20*47) mm	STRAIGHT	AKYD 108/24	104	47	2	50	200
60 mm	6204 (20*47) mm	STRAIGHT	AKYD 060/34	57	47	3	50	135
76 mm	6204 (20*47) mm	STRAIGHT	AKYD 076/34	72	47	3	50	235
89 mm	6204 (20*47) mm	STRAIGHT	AKYD 089/34	85	47	3	50	263
102 mm	6204 (20*47) mm	STRAIGHT	AKYD 102/34	98	47	3	50	280
108 mm	6204 (20*47) mm	STRAIGHT	AKYD 108/34	104	47	3	50	331
114 mm	6204 (20*47) mm	STRAIGHT	AKYD 114/34	110	47	3	50	360
127 mm	6204 (20*47) mm	STRAIGHT	AKYD 127/34	124	47	3	50	400
133 mm	6204 (20*47) mm	STRAIGHT	AKYD 133/34	127	47	3	50	437
159 mm	6204 (20*47) mm	STRAIGHT	AKYD 159/34	154	47	3	50	540
76 mm	6205 (25*52) mm	STRAIGHT	AKYD 076/35	72	52	3	50	235
89 mm	6205 (25*52) mm	STRAIGHT	AKYD 089/35	85	52	3	50	265
102 mm	6205 (25*52) mm	STRAIGHT	AKYD 102/35	98	52	3	50	320
108 mm	6205 (25*52) mm	STRAIGHT	AKYD 108/35	104	52	3	50	350
114 mm	6205 (25*52) mm	STRAIGHT	AKYD 114/35	110	52	3	50	370
127 mm	6205 (25*52) mm	STRAIGHT	AKYD 127/35	124	52	3	50	420
133 mm	6205 (25*52) mm	STRAIGHT	AKYD 133/35	127	52	3	50	480
159 mm	6205 (25*52) mm	STRAIGHT	AKYD 159/35	154	52	3	50	560
89 mm	6206 (30*62) mm	STRAIGHT	AKYD 089/36	85	62	3	50	297
108 mm	6206 (30*62) mm	STRAIGHT	AKYD 108/36	104	62	3	50	380
114 mm	6206 (30*62) mm	STRAIGHT	AKYD 114/36	110	62	3	50	380
127 mm	6206 (30*62) mm	STRAIGHT	AKYD 127/36	124	62	3	50	410
133 mm	6206 (30*62) mm	STRAIGHT	AKYD 133/36	127	62	3	50	520
159 mm	6206 (30*62) mm	STRAIGHT	AKYD 159/36	154	62	3	50	630

**AKYE;** DETERMINES ITS TYPE, 076; ITS PIPE DIAMETER, 2; MATERIAL THICKNESS, AND 4; ITS BEARING

## RUBBER DISCS

You can supply your needs regarding Impact's, Return's, Helix types, chocks, spiral rubbers, eraser rubbers, stripper rubbers, sieve seals, belt addition metal parts used in conveyors from our firm. Please request our current prices before giving order.

Roller Diameter To Be Used	Inner Diameter Of Ring $\varnothing$ UU	Outer Diameter Of Ring $\varnothing$ ZZ	Thickness Of Ring W	Type	Code
60 mm	56 mm	85 mm	35 mm	Impact	AKKD 600089
60 mm	56 mm	105 mm	35 mm	Impact	AKKD 600108
60 mm	56 mm	110 mm	35 mm	Impact	AKKD 600114
60 mm	56 mm	129 mm	35 mm	Impact	AKKD 600133
76 mm	72 mm	105 mm	35 mm	Impact	AKKD 760108
76 mm	72 mm	110 mm	35 mm	Impact	AKKD 760114
76 mm	72 mm	129 mm	35 mm	Impact	AKKD 760133
89 mm	85 mm	110 mm	35 mm	Impact	AKKD 890114
89 mm	85 mm	129 mm	35 mm	Impact	AKKD 890133
89 mm	85 mm	155 mm	35 mm	Impact	AKKD 890159
108 mm	104 mm	155 mm	35 mm	Impact	AKKD 108159
108 mm	104 mm	176mm	40 mm	Impact	AKKD 108180
114 mm	110 mm	155 mm	35 mm	Impact	AKKD 114159

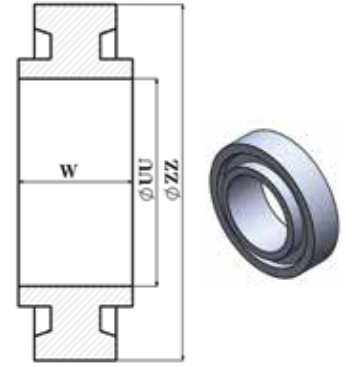

**AKKD;** DETERMINES ITS TYPE, 600; ITS PIPER DIAMETER, AND 108; DISC NOMINAL DIAMETER.

Roller Diameter To Be Used $\varnothing$ D	Inner Diameter Of Ring $\varnothing$ UU	Outer Diameter Of Ring $\varnothing$ ZZ	Thickness Of Ring W	Type	Code
60 mm	56 mm	85 mm	35 mm	Return	AKKS 600089
60 mm	56 mm	105 mm	35 mm	Return	AKKS 600108
60 mm	56 mm	110 mm	35 mm	Return	AKKS 600114
60 mm	56 mm	129 mm	35 mm	Return	AKKS 600133
76 mm	72 mm	105 mm	35 mm	Return	AKKS 760108
76 mm	72 mm	110 mm	35 mm	Return	AKKS 760114
76 mm	72 mm	129 mm	35 mm	Return	AKKS 760133
89 mm	85 mm	110 mm	35 mm	Return	AKKS 890114
89 mm	85 mm	129 mm	35 mm	Return	AKKS 890133
89 mm	85 mm	155 mm	35 mm	Return	AKKS 890159
108 mm	104 mm	155 mm	35 mm	Return	AKKS 108159
108 mm	104 mm	176mm	40 mm	Return	AKKS 108180
114 mm	110 mm	155 mm	35 mm	Return	AKKS 114159

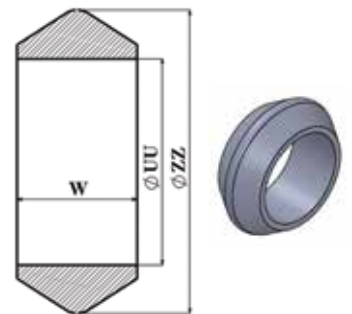

**AKKS;** DETERMINES ITS TYPE, 600; ITS PIPER DIAMETER, AND 89; DISC NOMINAL DIAMETER.



## ORDER FORM

All rollers and Drums are being made according to the order. Please specify list of measurements and serial numbers.

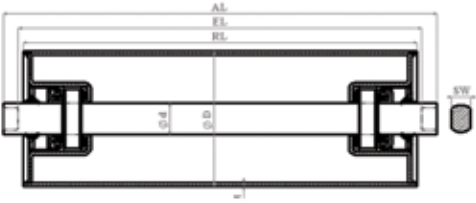
D		PIPE DIAMETER	<p style="text-align: center;"><b>CARRYING ROLLER</b></p> 
RL		PIPE LENGTH	
AL		EXACT SHAFT LENGTH	
EL		AA CENTER	
d		SHAFT DIAMETER	
ROLLER CODE NO			
SW AA CODE NO			
AMOUNT			

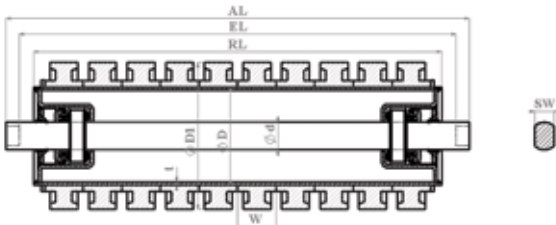
D		PIPE DIAMETER	<p style="text-align: center;"><b>IMPACT ROLLER</b></p> 
D1		DISC DIAMETER	
RL		PIPE LENGTH	
AL		EXACT SHAFT LENGTH	
EL		AA CENTER	
d		SHAFT DIAMETER	
ROLLER CODE NO			
SW AA CODE NO			
AMOUNT			

D		PIPE DIAMETER	<p style="text-align: center;"><b>RETURN ROLLER</b></p> 
D1		DISC DIAMETER	
RL		PIPE LENGTH	
AL		EXACT SHAFT LENGTH	
EL		AA CENTER	
d		SHAFT DIAMETER	
ROLLER CODE NO			
SW AA CODE NO			
AMOUNT			

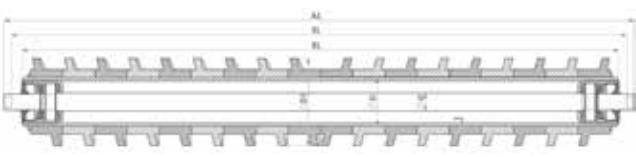
D		PIPE DIAMETER	<p style="text-align: center;"><b>HELIX DISC ROLLER</b></p> 
D1		DISC DIAMETER	
RL		PIPE LENGTH	
AL		EXACT SHAFT LENGTH	
EL		AA CENTER	
d		SHAFT DIAMETER	
ROLLER CODE NO			
SW AA CODE NO			
AMOUNT			

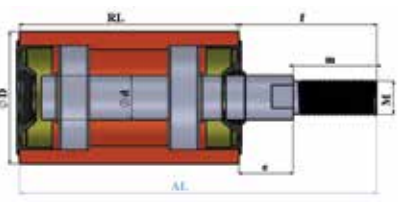
D		PIPE DIAMETER	<p style="text-align: center;"><b>GUIDE ROLLER</b></p> 
RL		PIPE LENGTH	
AL		EXACT SHAFT LENGTH	
d		SHAFT DIAMETER	
M		THREAD SIZE	
m		THREAD LENGTH	
ROLLER CODE NO			
SW AA CODE NO			
AMOUNT			

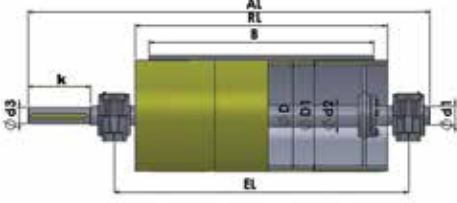
D	PIPE DIAMETER	 <p style="text-align: center;"><b>DRIVING DRUM</b></p>
D1	RUBBERED DIAMETER	
RL	PIPE LENGTH	
AL	EXACT SHAFT LENGTH	
EL	HOUSING CENTER	
d1	BEARING INNER DIAMETER	
d3	REDUCER SHAFT DIAMETER	
DRUM CODE NO		
AMOUNT		

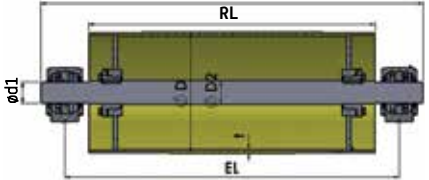
D	PIPE DIAMETER	 <p style="text-align: center;"><b>TAIL/TENSION/ DIVERSION DRUM</b></p>
D1	RUBBERED DIAMETER	
RL	PIPE LENGTH	
AL	EXACT SHAFT LENGTH	
EL	HOUSING CENTER	
d1	BEARING INNER DIAMETER	
DRUM CODE NO		
AMOUNT		

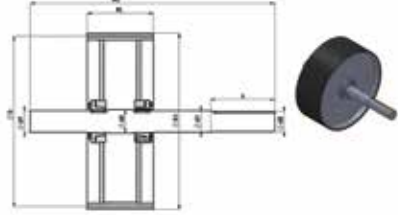
D	PIPE DIAMETER	 <p style="text-align: center;"><b>ELEVATOR DRIVING DRUM</b></p>
D1	RUBBERED DIAMETER	
RL	PIPE LENGTH	
AL	EXACT SHAFT LENGTH	
EL	HOUSING CENTER	
d1	BEARING INNER DIAMETER	
d3	REDUCER SHAFT DIAMETER	
DRUM CODE NO		
AMOUNT		

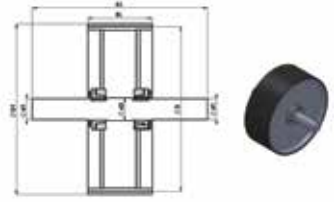
D	PIPE DIAMETER	 <p style="text-align: center;"><b>ELEVATOR TAIL DRUM</b></p>
D1	RUBBERED DIAMETER	
RL	PIPE LENGTH	
AL	EXACT SHAFT LENGTH	
EL	HOUSING CENTER	
d1	BEARING INNER DIAMETER	
DRUM CODE NO		
AMOUNT		

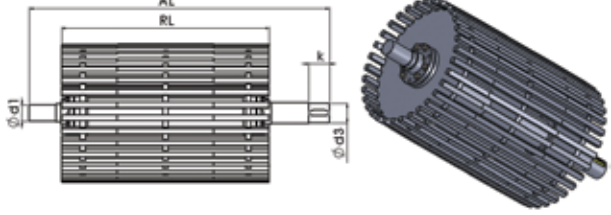
D	PIPE DIAMETER	 <p style="text-align: center;"><b>BARRED CLEANING DRIVING DRUM</b></p>
D1	RUBBERED DIAMETER	
RL	PIPE LENGTH	
AL	EXACT SHAFT LENGTH	
EL	HOUSING CENTER	
d1	BEARING INNER DIAMETER	
d3	REDUCER SHAFT DIAMETER	
DRUM CODE NO		
AMOUNT		

D	PIPE DIAMETER	 <p style="text-align: center;"><b>BARRED CLEANING TAIL DRUM</b></p>
D1	RUBBERED DIAMETER	
RL	PIPE LENGTH	
AL	EXACT SHAFT LENGTH	
EL	HOUSING CENTER	
d1	BEARING INNER DIAMETER	
DRUM CODE NO		
AMOUNT		

## SOME OF OUR REFERENCES



### COUNTRIES WE EXPORT

GERMANY	KOSOVO	TUNISIA	IRAN
GREECE	NORWAY	JORDAN	PAKISTAN
BULGARIA	NETHERLANDS	IRAQ	GHANA
BELGIUM	ROMANIA	EGYPT	SINGAPOR
IRELAND	CYPRUS	KUWAIT	TANZANIA
MACEDONIA		ALGERIA	ETHIOPIA
SPAIN		QATAR	TOGO
SERBIA		SAUDI ARABIA	SUDAN
AUSTRIA		UAE	GEORGIA
BRITAIN		LIBYA	TURKMENISTAN
LITHUANIA		SYRIA	KAZAKHSTAN
HUNGARY		YEMEN	AZERBAIJAN
SWITZERLAND		MOROCCO	ISRAEL
BOSNIA AND HERZEGOVINA		LEBANON	

Address:

1.Organize Sanayi Bölgesi Akhun Caddesi No:4  
Sincan/ANKARA –TÜRKİYE

**T: +90 (312) 354 40 45**

**T: +90 (312) 267 07 57**

**F: +90 (312) 385 33 26**

E-mail:

[akkayalar@akkayalar.com.tr](mailto:akkayalar@akkayalar.com.tr)

[export@akkayalar.com.tr](mailto:export@akkayalar.com.tr)

**[www.akkayalar.com.tr](http://www.akkayalar.com.tr)**



[akkayalarkonveyor](#)



[akkayalar-konveyör](#)



[akkayalar\\_tr](#)



[Akkayalar Konveyör](#)